



UNIVERSITÀ
di **VERONA**

Dipartimento
di **INFORMATICA**

Corso di Laboratorio Ciberfisico
Modulo di Robot Programming with ROS

Percezione *visione*

Docente:
**Domenico Daniele
Bloisi**

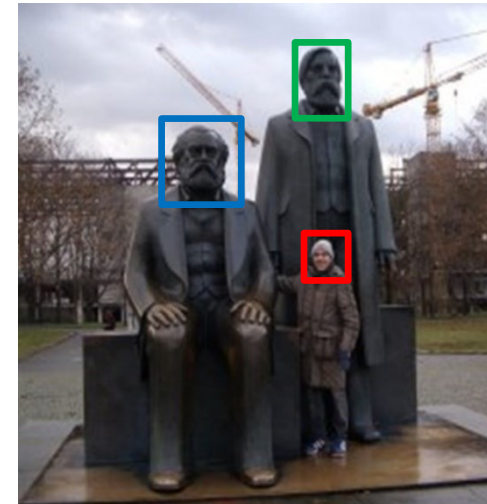
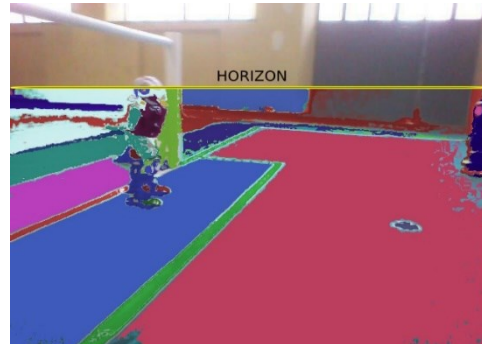
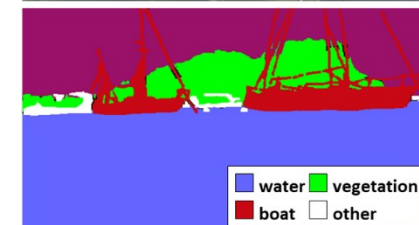
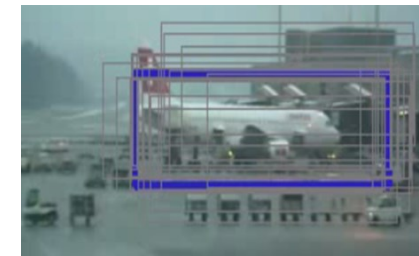

Maggio 2018

See-Think-Act Cycle

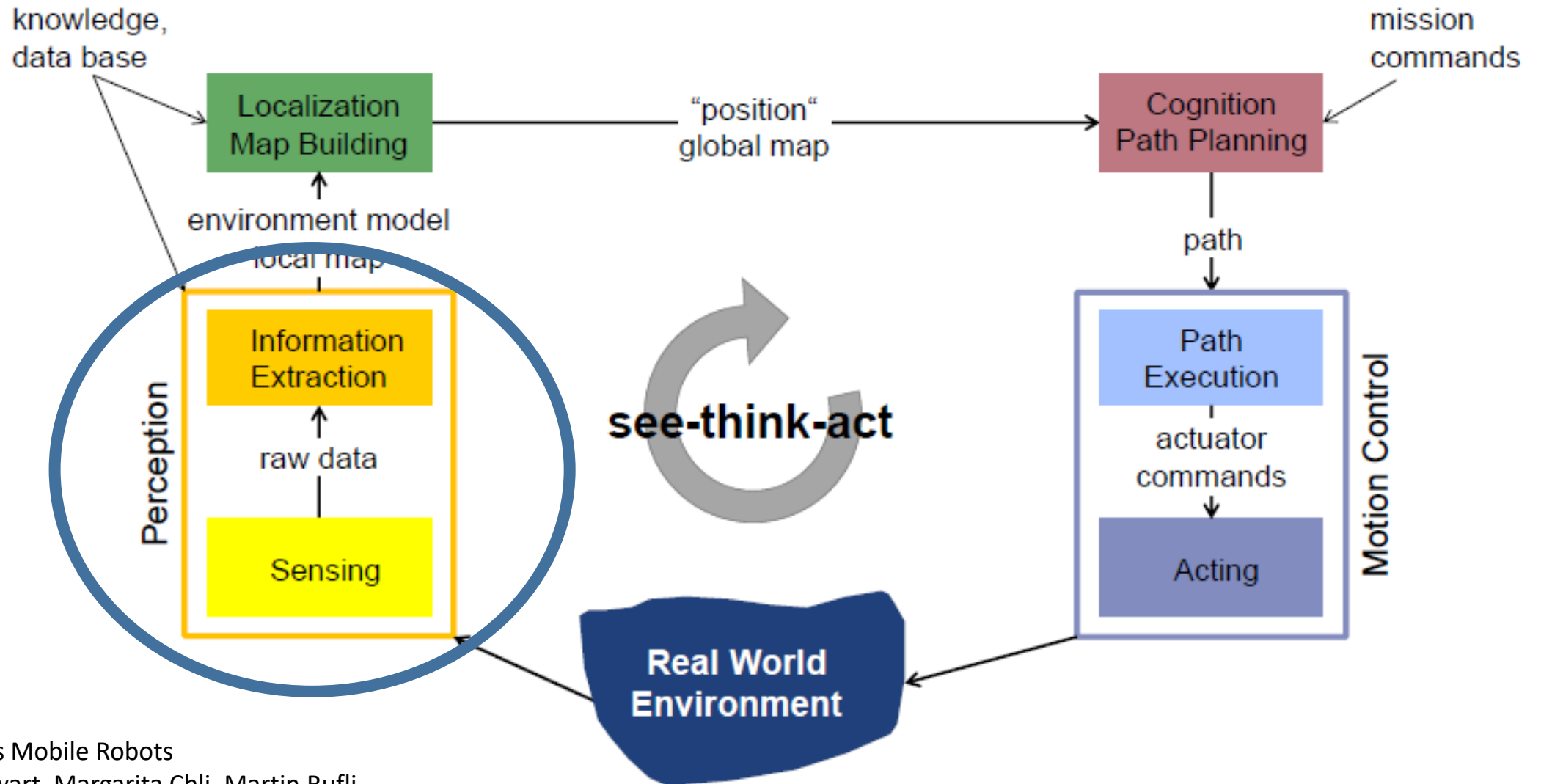

Percezione

- Laser scanner
 - time of flight

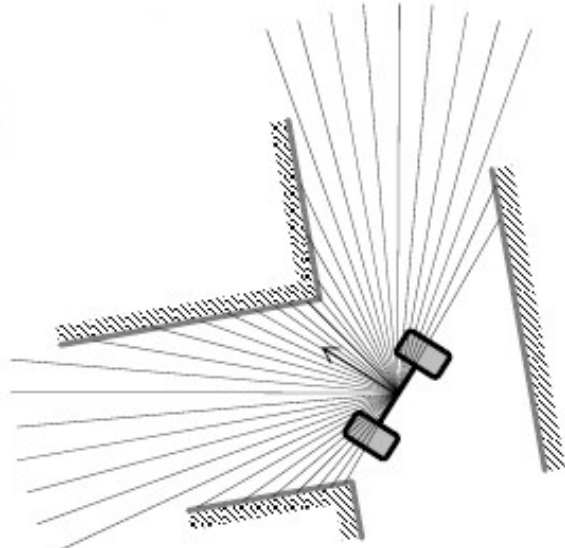

- Camera

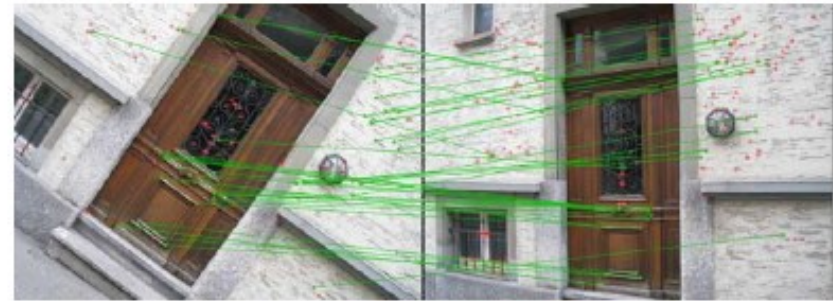
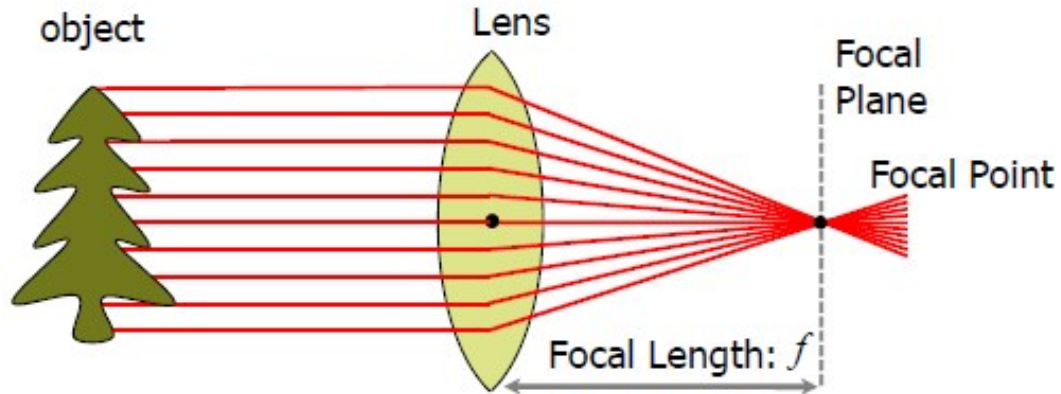

Percezione per robot mobili

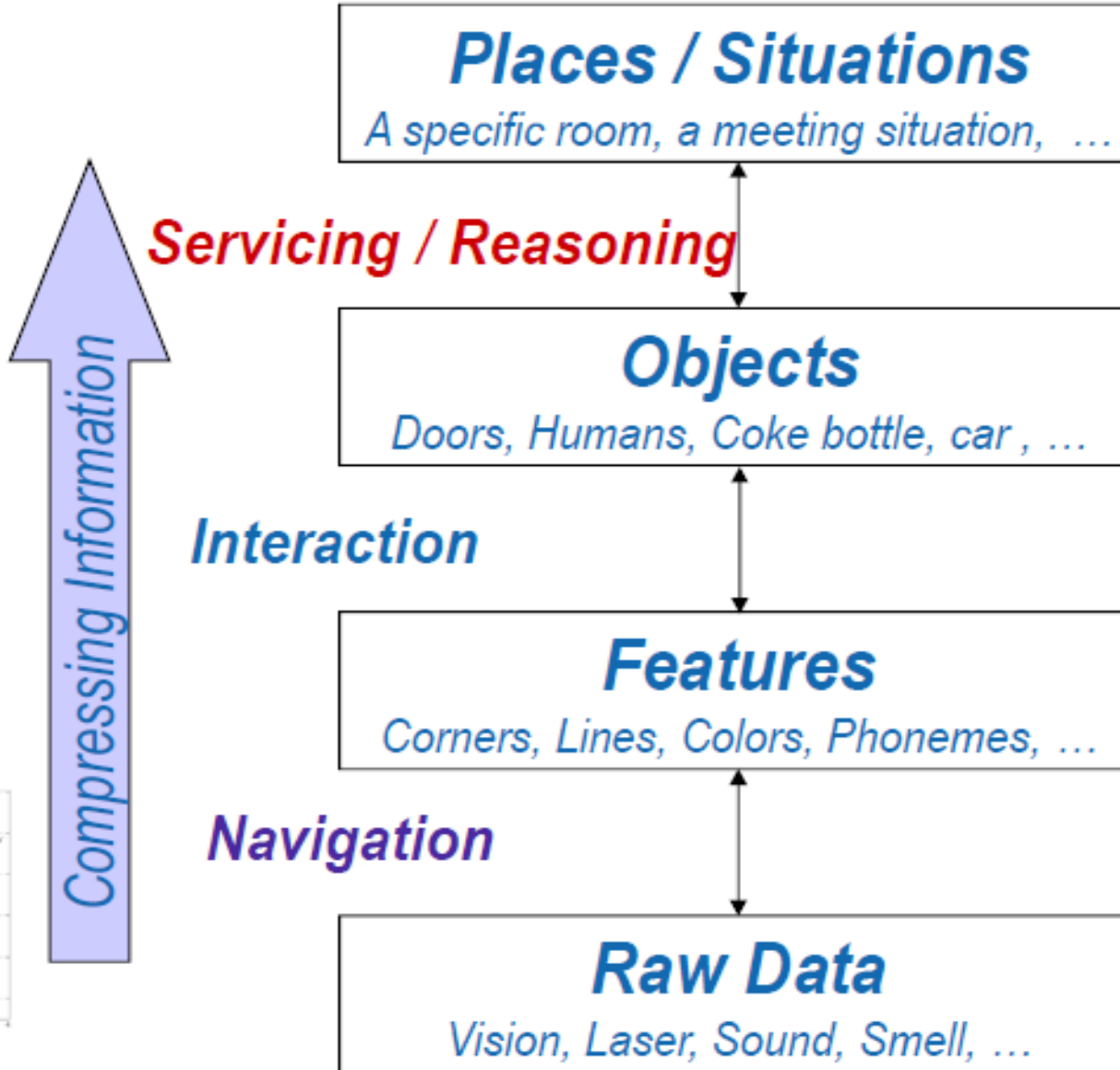
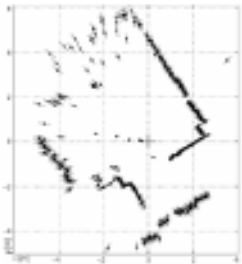
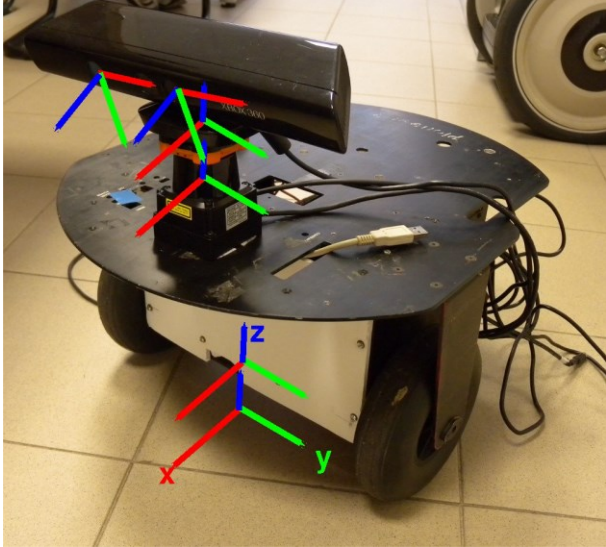

Informazioni geometriche e semantiche

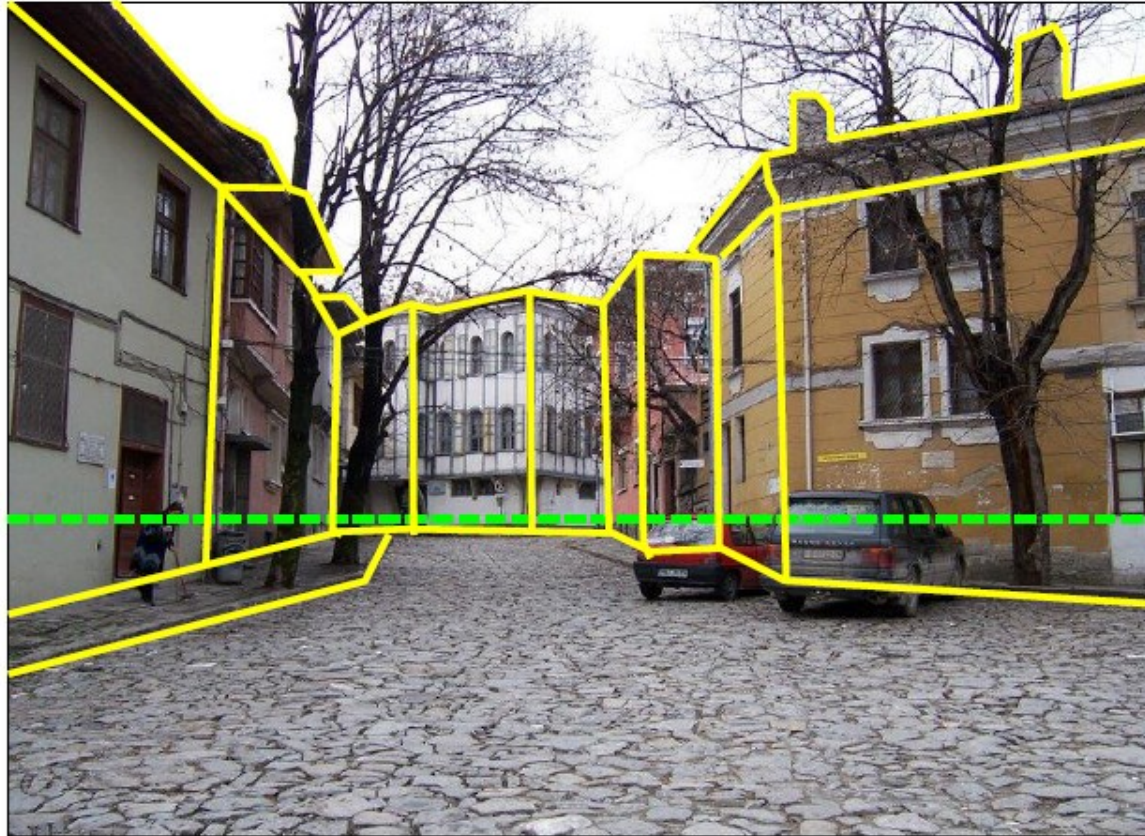

informazioni geometriche



informazioni semantiche

Percezione visuale

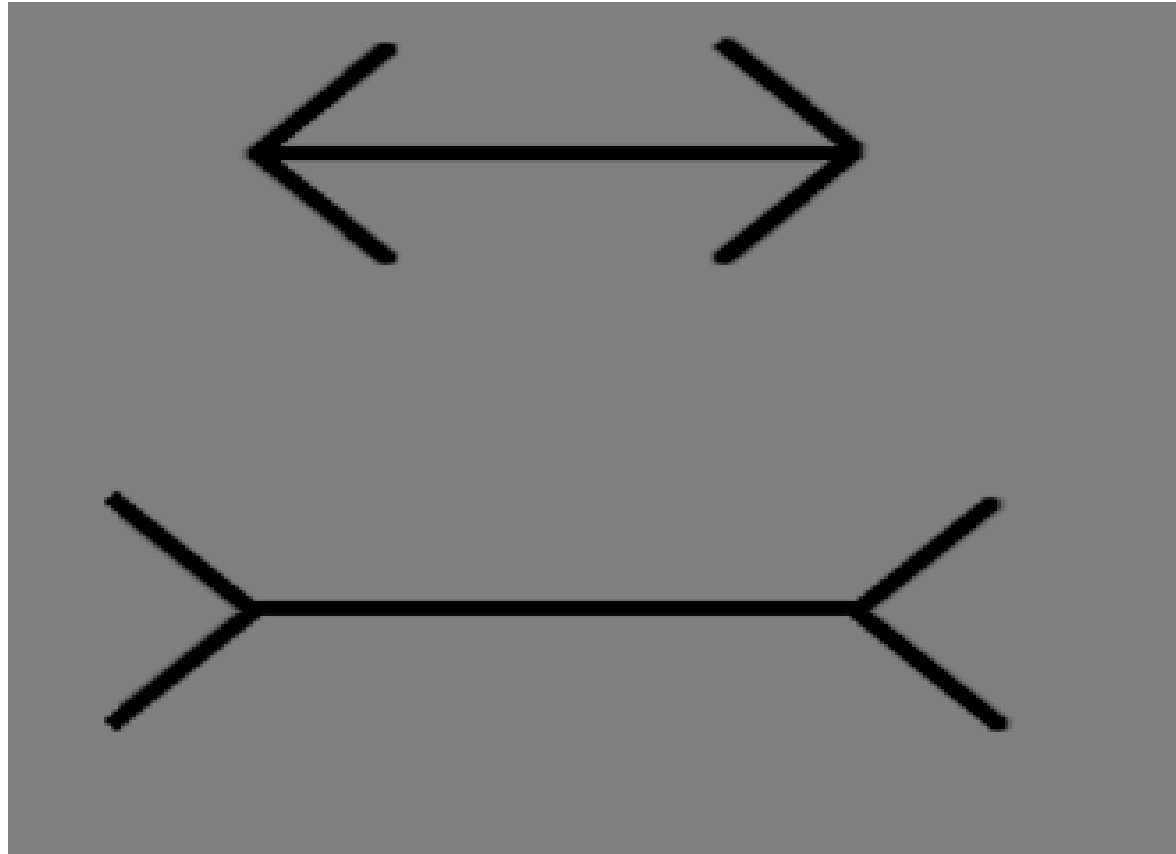

Percezione visuale

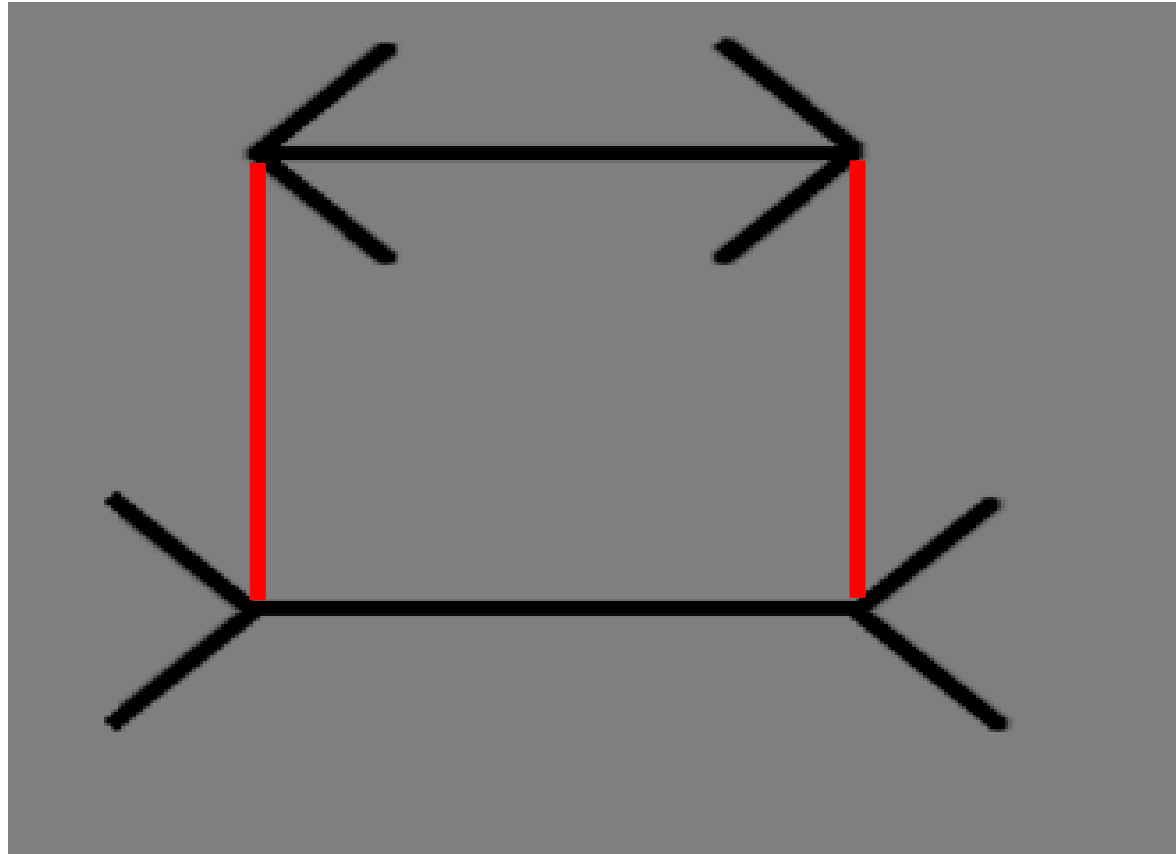

Illusioni ottiche

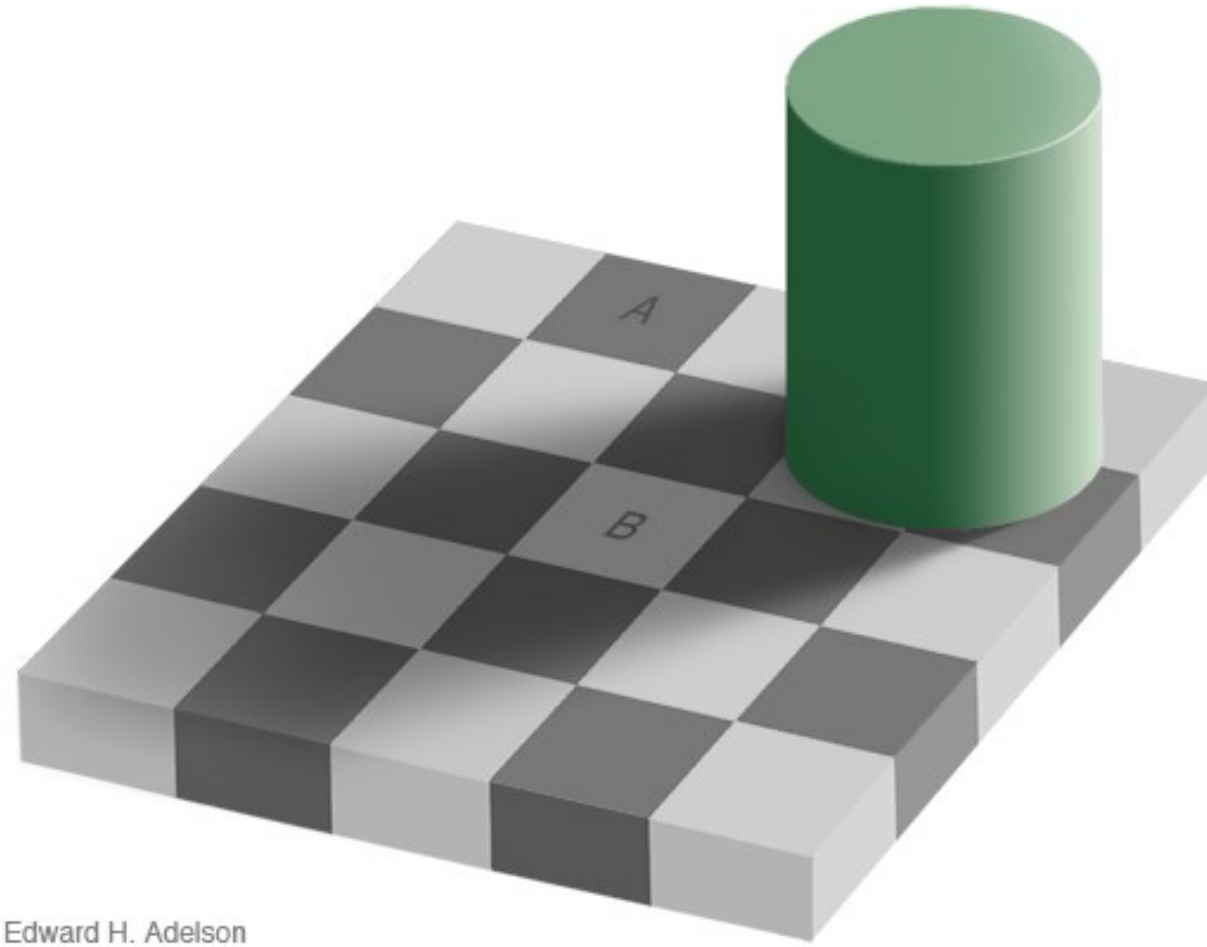

Edward H. Adelson

Illusioni ottiche

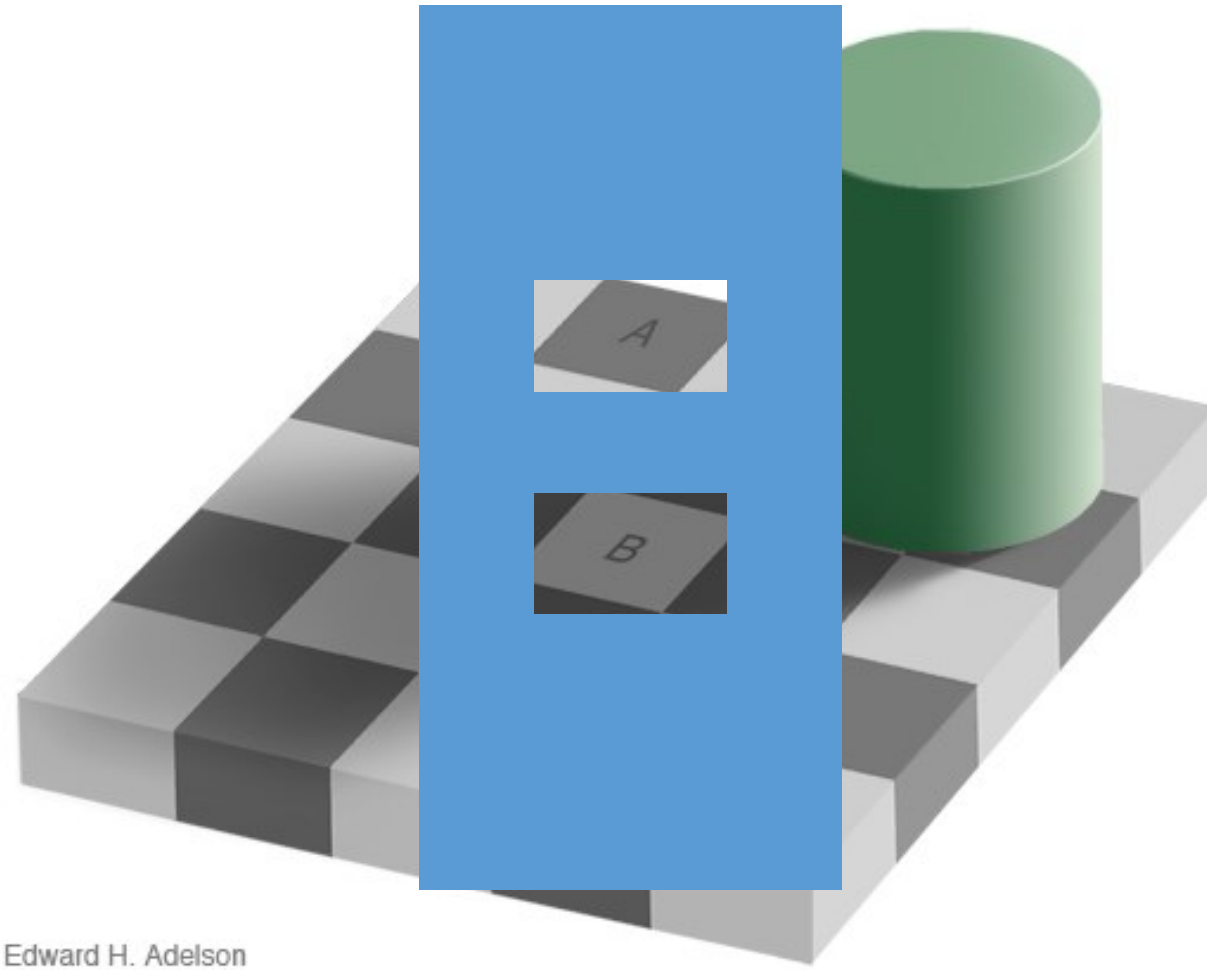

Edward H. Adelson

Illusioni ottiche

Autonomous Mobile Robots
Margarita Chli, Martin Rufli, Roland Siegwart

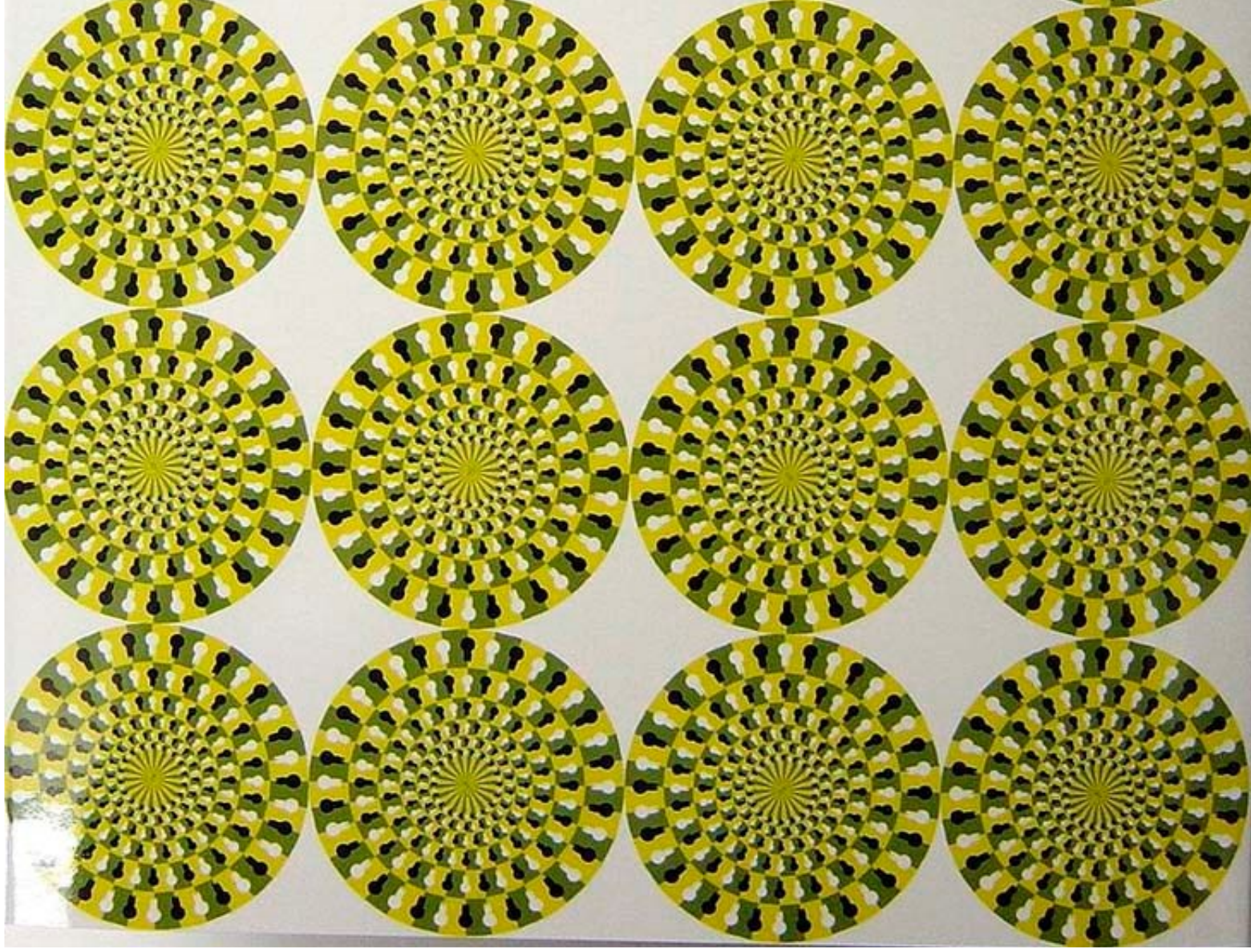

www.donparrish.com/FavoriteOpticalIllusion.html

Trova il punto verde



Trova il punto verde



Immagine Digitale

- Una immagine digitale è una matrice di pixel
- Il termine pixel deriva da *picture element*
- Il pixel contiene l'informazione relativa alla rappresentazione della realtà che è stata catturata tramite uno scanner, una macchina fotografica o un frame grabber (per i video)

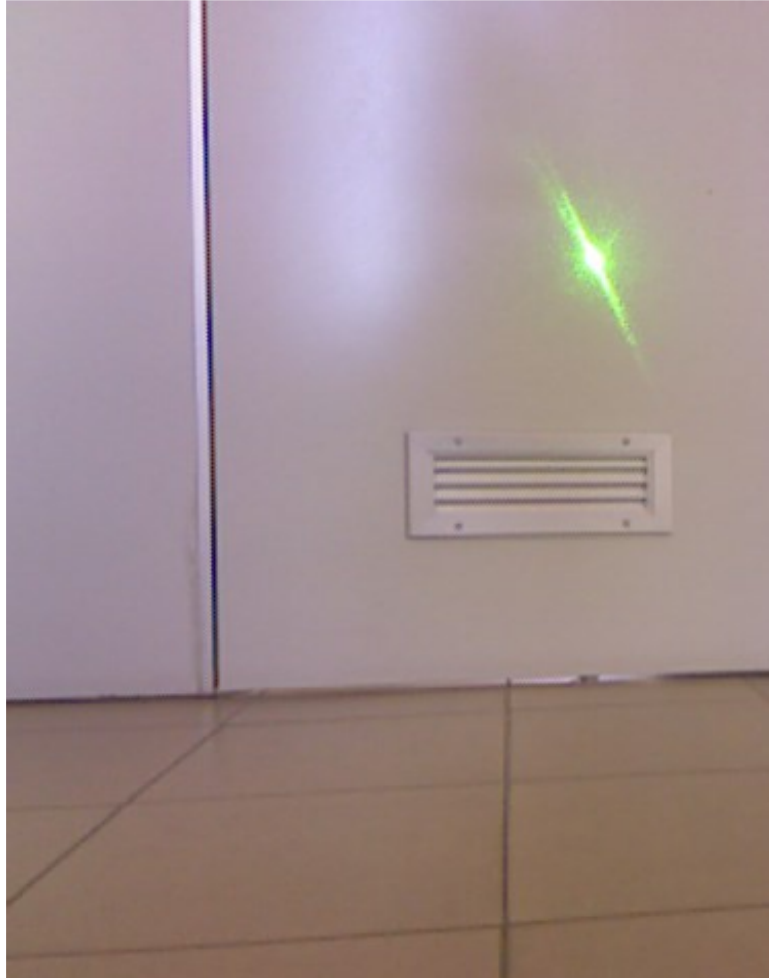

But the camera sees this:

194	210	201	212	199	213	215	195	178	158	182	209
180	189	190	221	209	205	191	167	147	115	129	163
114	126	140	188	176	165	152	140	170	106	78	88
87	103	115	154	143	142	149	153	173	101	57	57
102	112	106	131	122	138	152	147	128	84	58	66
94	95	79	104	105	124	129	113	107	87	69	67
68	71	69	98	89	92	98	95	89	88	76	67
41	56	68	99	63	45	60	82	58	76	74	65
20	41	69	75	56	41	51	73	55	70	63	44
50	50	57	69	75	75	73	74	53	68	59	37
72	59	53	66	84	92	84	74	57	72	63	42
67	61	58	65	75	78	76	73	59	75	69	50

Dimensioni

- La dimensione dell'immagine è rappresentata dal numero dei pixel che la compongono
- Per esprimere la dimensione si usa il formato:

WxH

dove *W* indica il numero di pixel orizzontali e *H* il numero di pixel verticali

Esempio: 640x480 pixel



Risoluzione

Con il termine risoluzione si indica la densità dei pixel in relazione alla dimensione del supporto di visualizzazione (per esempio un foglio di carta o uno schermo)

- Si esprime comunemente in pixel per inch (**ppi**) o dot per inch (**dpi**)
- Ad esempio, nel caso si voglia stampare una immagine potremo selezionare la risoluzione attraverso un valore del tipo *300 dpi*
- La risoluzione può essere vista come la capacità di dettaglio di una immagine. Più è grande la risoluzione migliore è la discriminazione dei dettagli.

Risoluzione: esempio pratico



24 pollici
(Grandezza dello
schermo)

Dimensioni
1920×1080
cioè Full HD

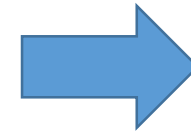

Risoluzione
91,79 ppi

Dimensioni
3840×2160
cioè Ultra HD (4k)

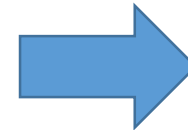

Risoluzione
183,58 ppi

Profondità di colore

- Ogni pixel contiene un quantità di informazione che può essere espressa in **bit** (binary digit).
- il numero di bit riservati per ogni pixel viene denominato **profondità di colore**
- Data la profondità di colore N , il numero di possibili tonalità per una immagine digitale è 2^N

Esempi:

$N = 1 \Rightarrow 2$ tonalità

$N = 4 \Rightarrow 16$ tonalità

$N = 8 \Rightarrow 256$ tonalità

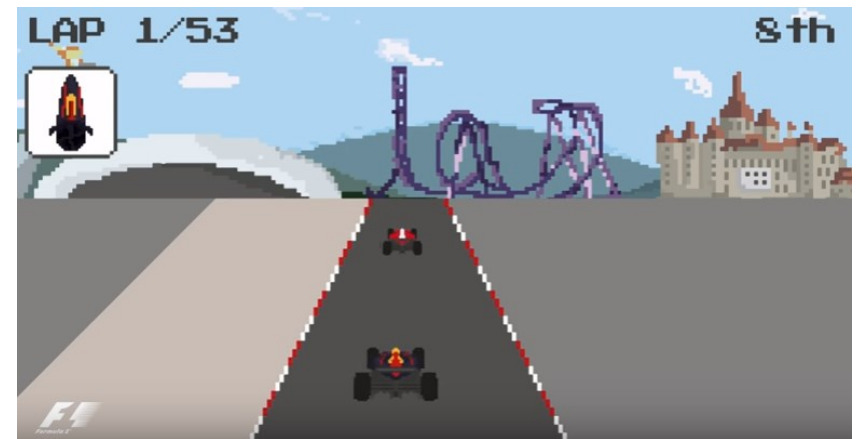

The F1 Story Of 2016: 8-Bit, Video-Game-Style!

https://www.youtube.com/watch?v=U4E9Qx5_ITY

Immagini e colori

- Immagine binaria (0 e 1)
- Immagine in scala di grigi (valori da 0-255)
- Immagine a colori (canali RGB)

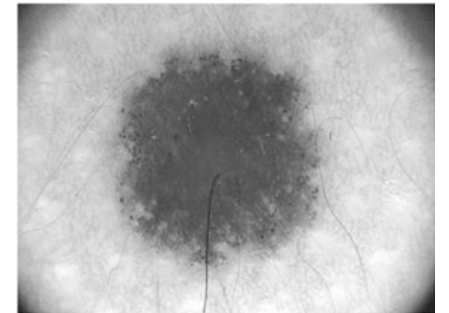
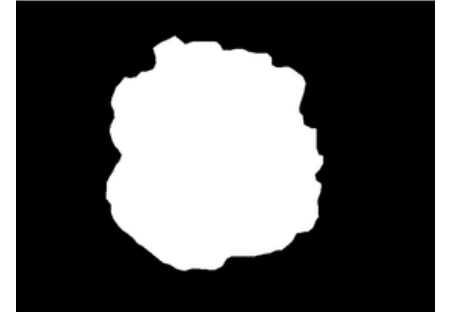

Ricostruzione 3D da immagini

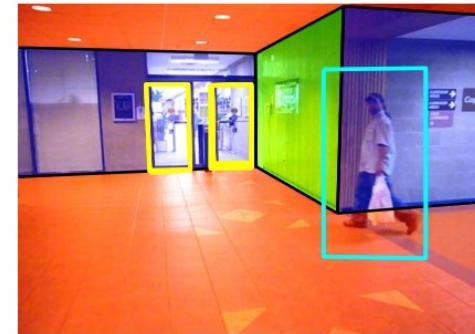
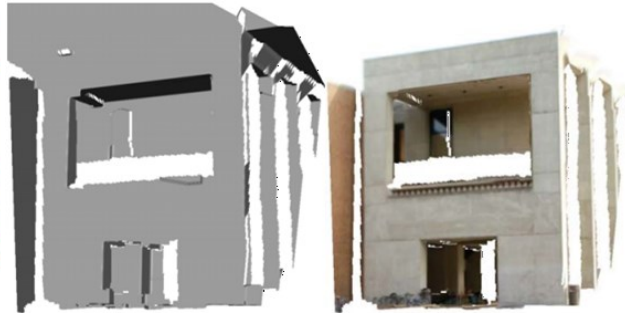
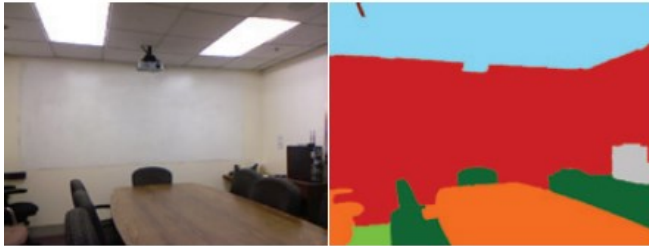

Point Cloud (PC):
Depth information
Image Saliency

Multi View (MV):
Multiple Image
Saliency

Single View (SV):
Image Saliency

[Silberman et al. 2011]

[Fukurawa et al. 2009]

[Lee et al. 2009]

Stereo Visione

L'analisi stereo è il processo di misurazione della distanza da un oggetto, basato sul confronto di due o più immagini dell'oggetto stesso ottenute simultaneamente.

La percezione della terza dimensione, che avvertiamo attraverso i nostri occhi, deriva dal fatto che i due bulbi oculari hanno i loro assi ottici distanti circa 65 mm e forniscono due immagini leggermente diverse degli oggetti che, sommando i loro effetti, procurano il senso della profondità

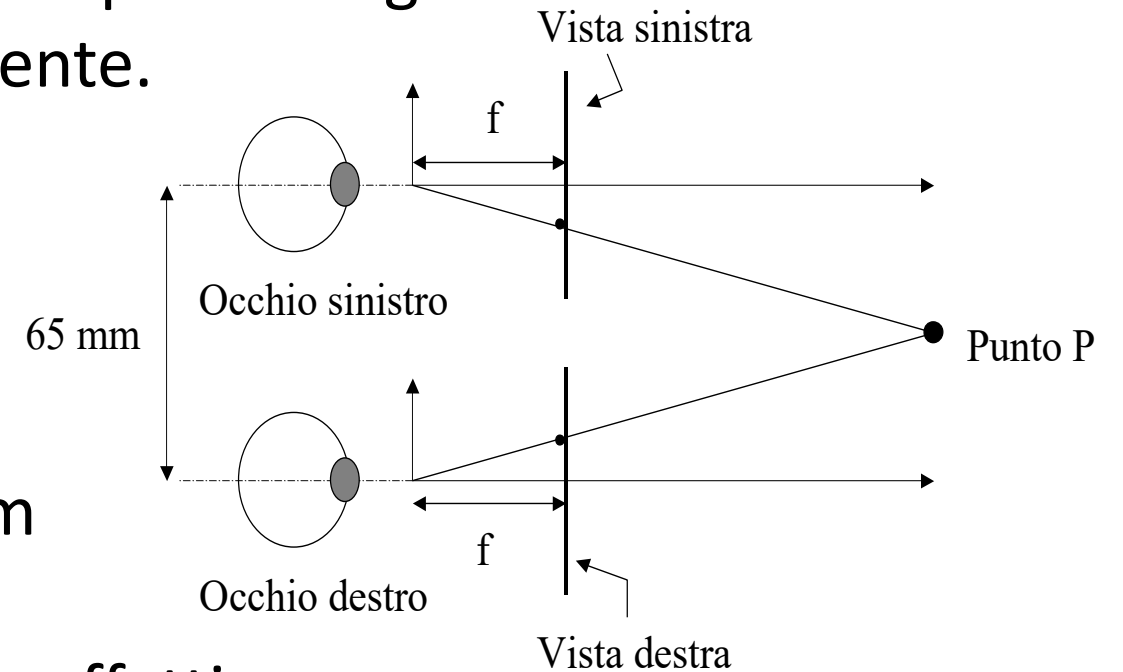

Stereogramma

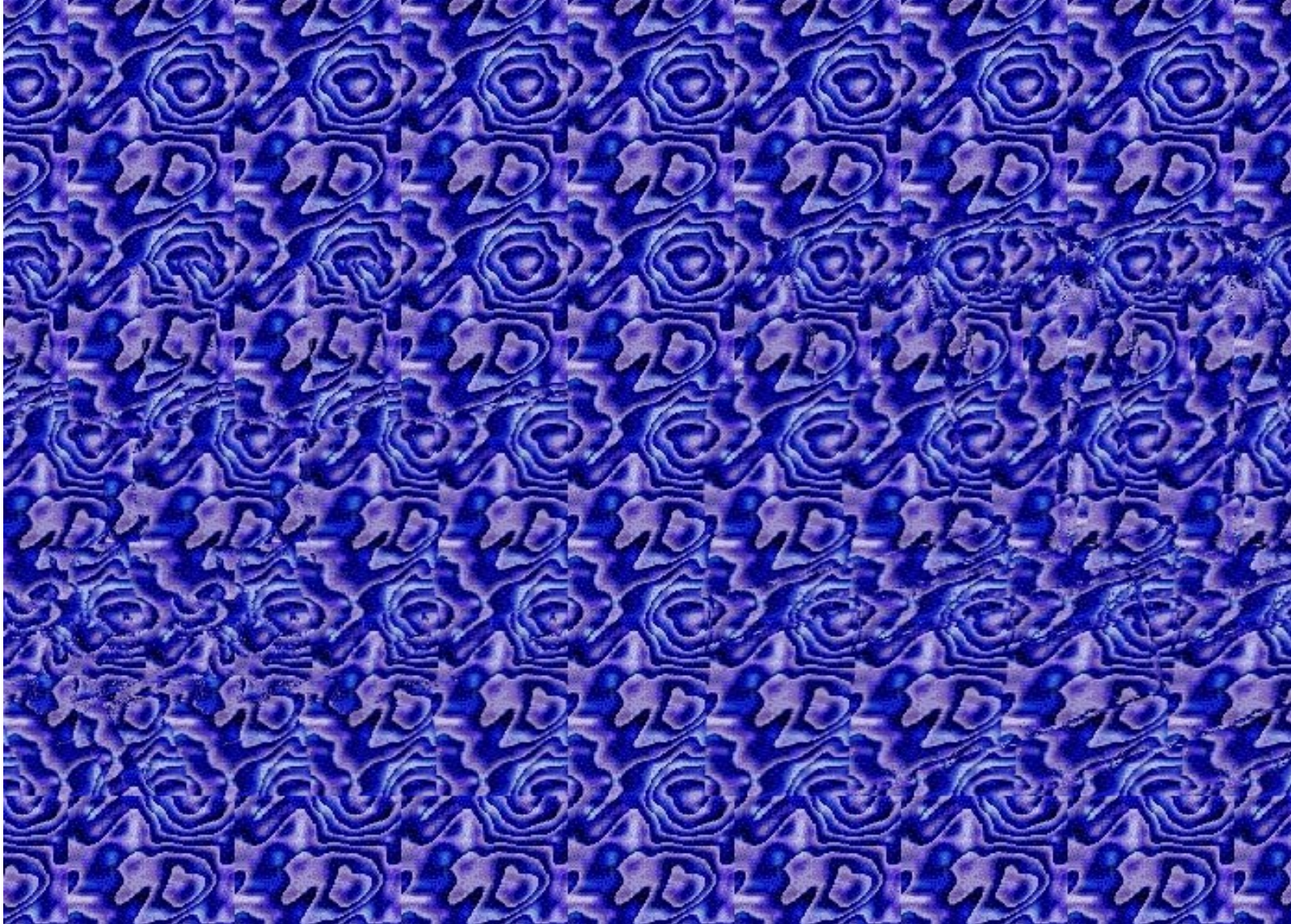

Correlazione tra punti

Il problema fondamentale nell'analisi stereo è quello di trovare la corrispondenza tra gli elementi delle varie immagini disponibili.

Una volta che tale corrispondenza è stata scoperta, la distanza dall'oggetto può essere ottenuta tramite l'ottica geometrica.

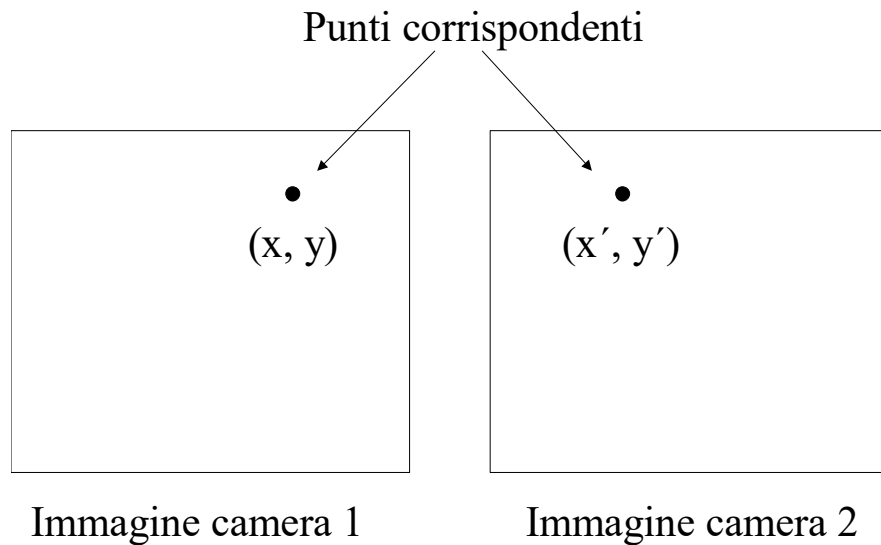

La coppia di locazioni (x, y) e (x', y') è unica. Proprio perché tale coppia è unica, se si riescono a trovare le due locazioni che corrispondono allo stesso identico punto nello spazio, allora è possibile risalire alle coordinate tridimensionali di detto punto.

Correlazione area-based

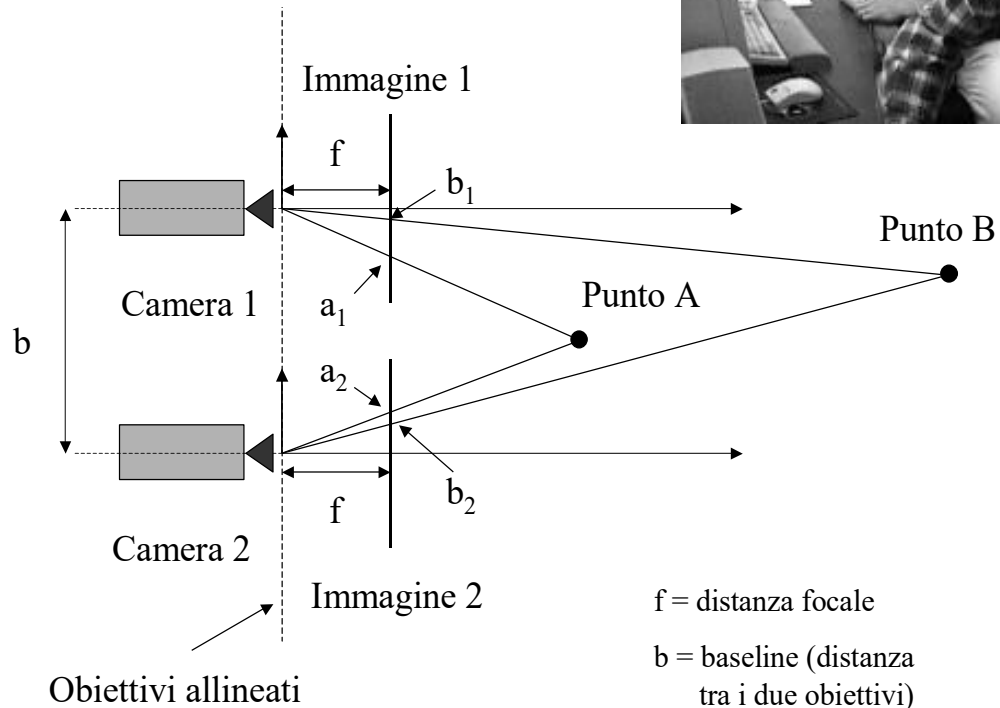

disparità per il punto A: $d(A) = a_1 - a_2$

disparità per il punto B: $d(B) = b_1 - b_2$

Troviamo $d(A) > d(B)$, poiché $a_1 > b_1$ e $a_2 < b_2$

Rettificazione e Mappa di disparità



Coppia stereo
rettificata

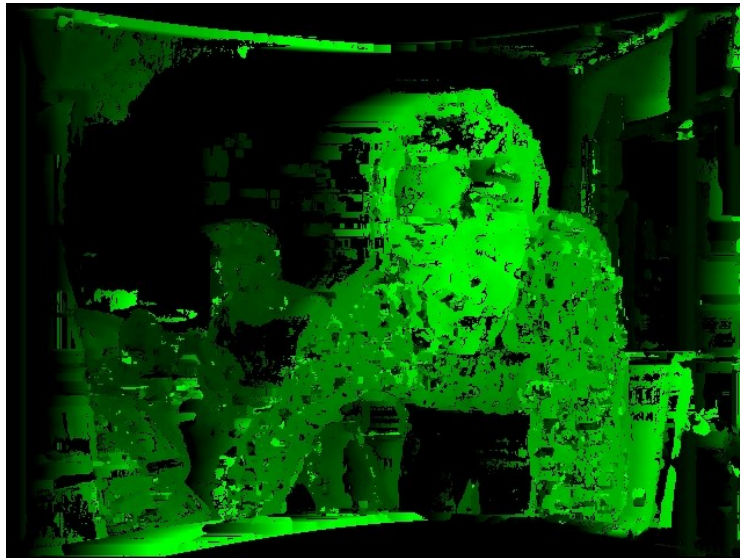

Mappa di disparità

Ricostruzione 3D con stereo visione

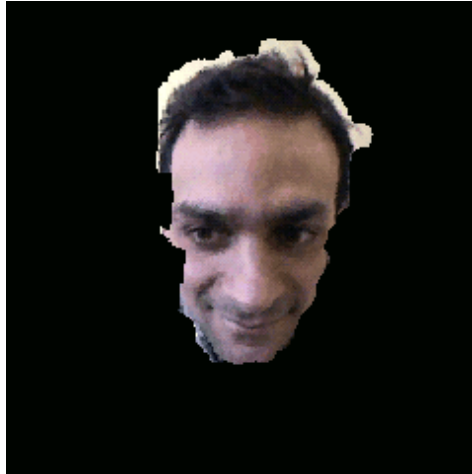

Microsoft Kinect

- Il sensore Kinect è stato lanciato in Nord America il 4 Novembre 2010
- Il Kinet è un sensore di movimento in grado di fornire informazioni 3D



Sensori del Kinect

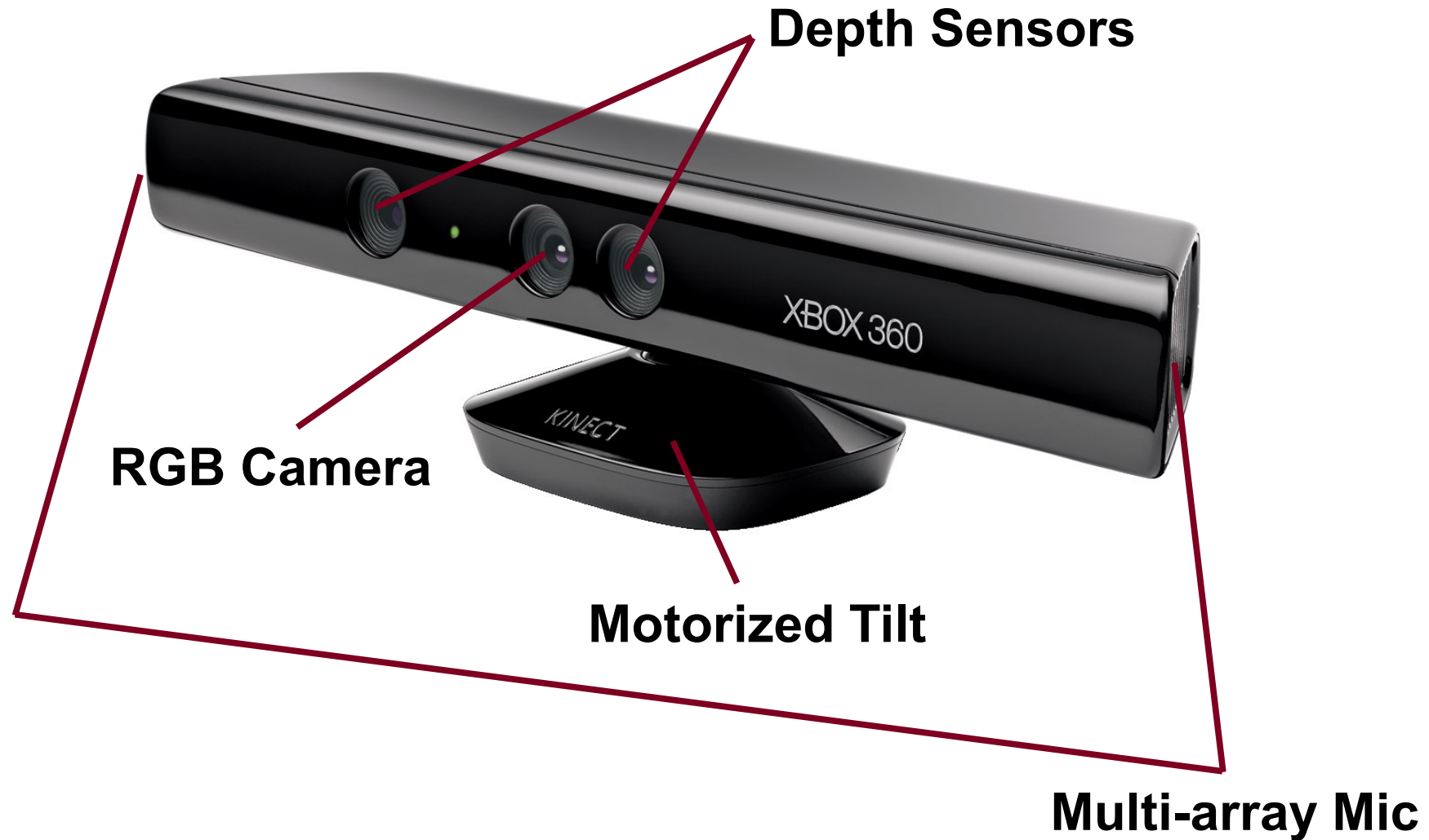

Sensori di Disparità

- Consiste in un proiettore di raggi infrarosso (IR) e un sensore CMOS
- L'IR beam riflette sul soggetto e viene catturato dal sensore CMOS
 - 640x480 pixel a 30 frame al secondo (fps)

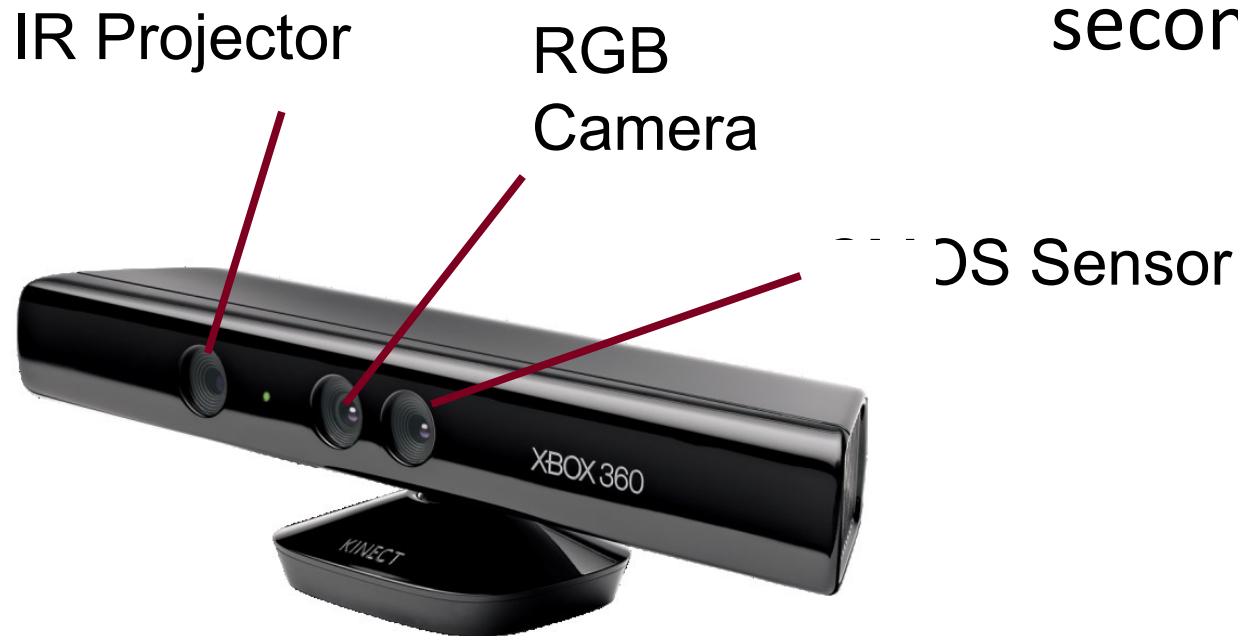

Stima della disparità



Il tempo di ritorno viene usato per misurare la distanza degli oggetti dal sensore



Immagine a colori + immagine di disparità

24-bit RGB data

11-bit depth data



Mappa di disparità densa

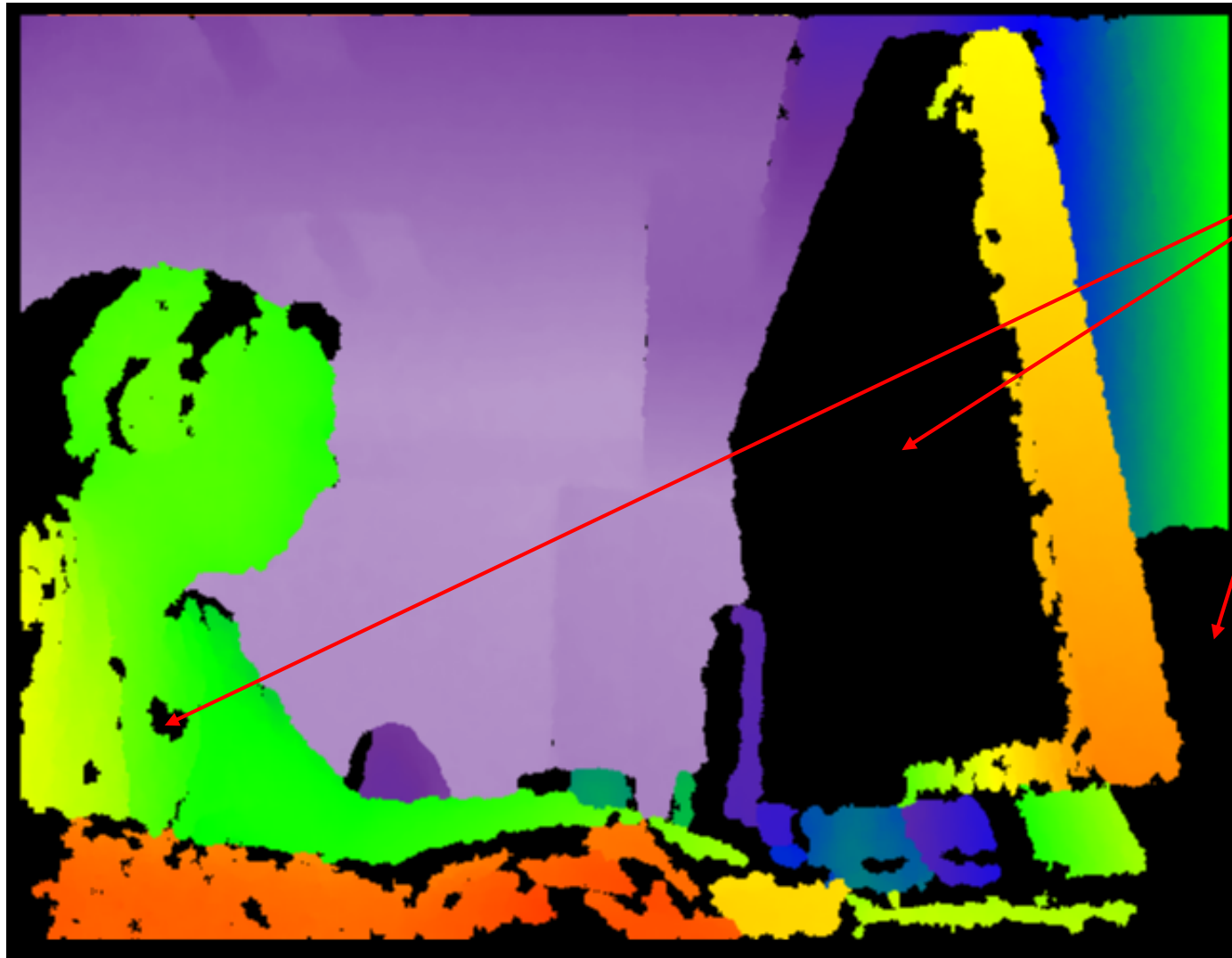

no depth
information

Limiti fisici del Microsoft Kinect

Angular field of view:
57° horizontally

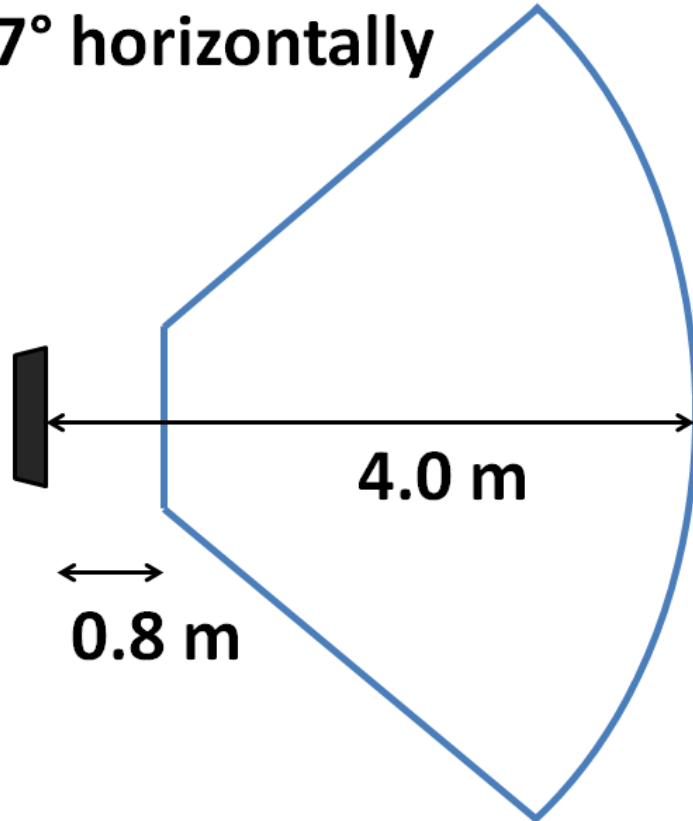

Angular field of view:

43° vertically

Tilt up to 27° up or down

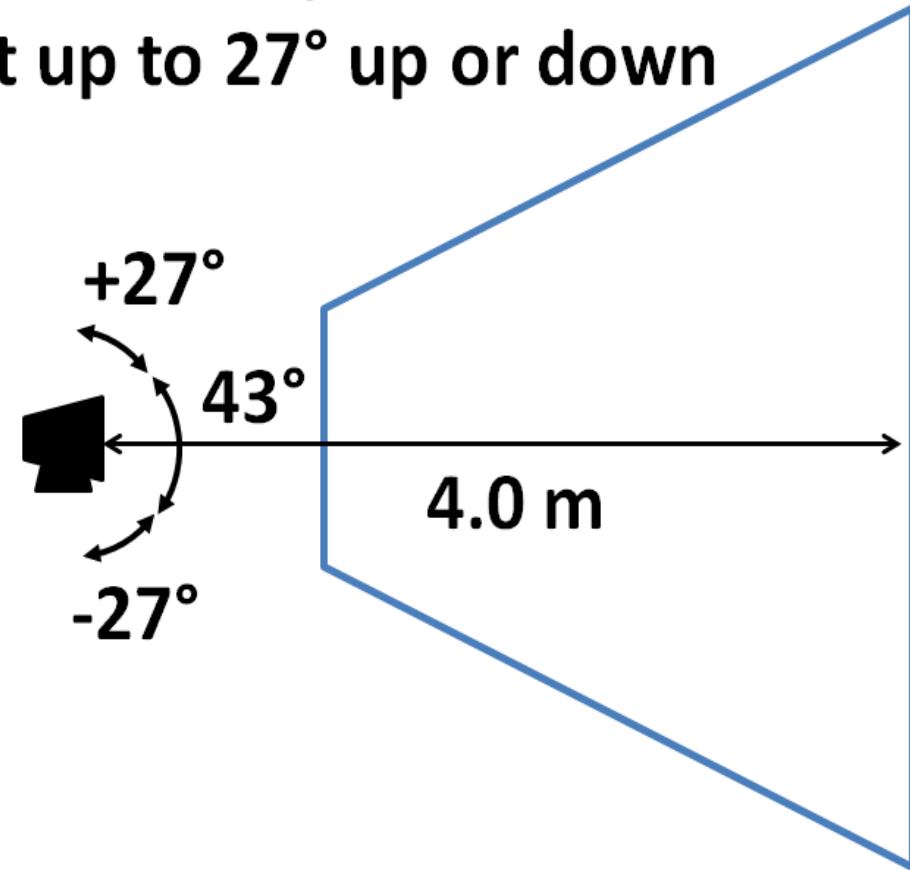

Ricostruzione 3D con Microsoft Kinect

<http://graphics.stanford.edu/~mdfisher/Kinect.html>

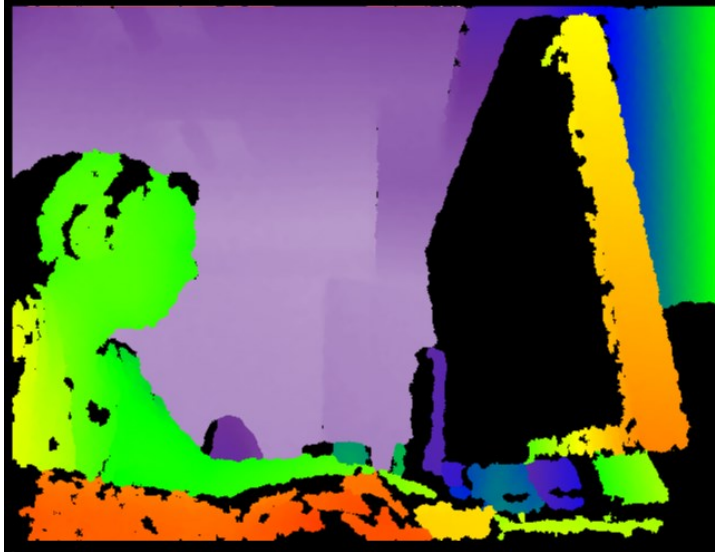

← point cloud

Esempio Kinect

Online Simultaneous Localization and Mapping
with
RTAB-Map and TORO on ROS

Mathieu Labbé

www.rtabmap.googlecode.com



January 2013

Link al video: <https://www.youtube.com/watch?v=AMLwjo80WzI>

Kinect 2.0 & Intel RealSense

- Typical characteristic
 - Resolution 1920x1080 pixels
 - Field of view: 70 deg (H), 60 deg (V)
 - Claimed accuracy: 1 mm
 - Claimed max range: 6 meters

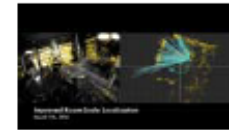

<https://www.youtube.com/watch?v=yvgPrZNp4So>



Riconoscimento di oggetti nelle immagini

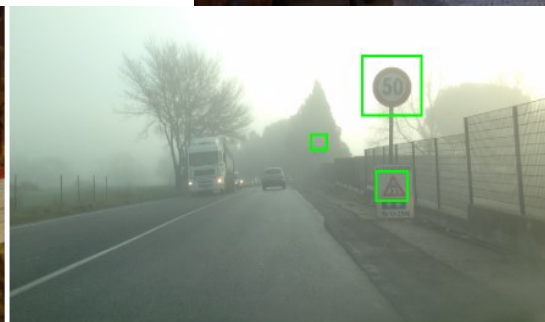
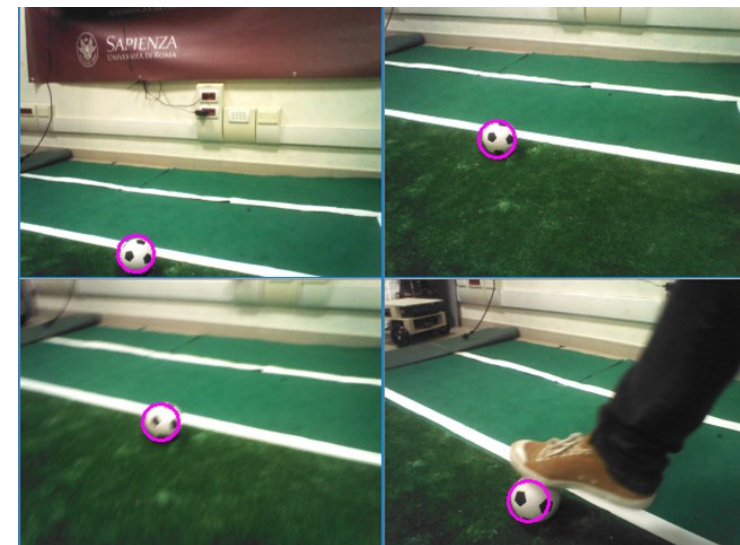
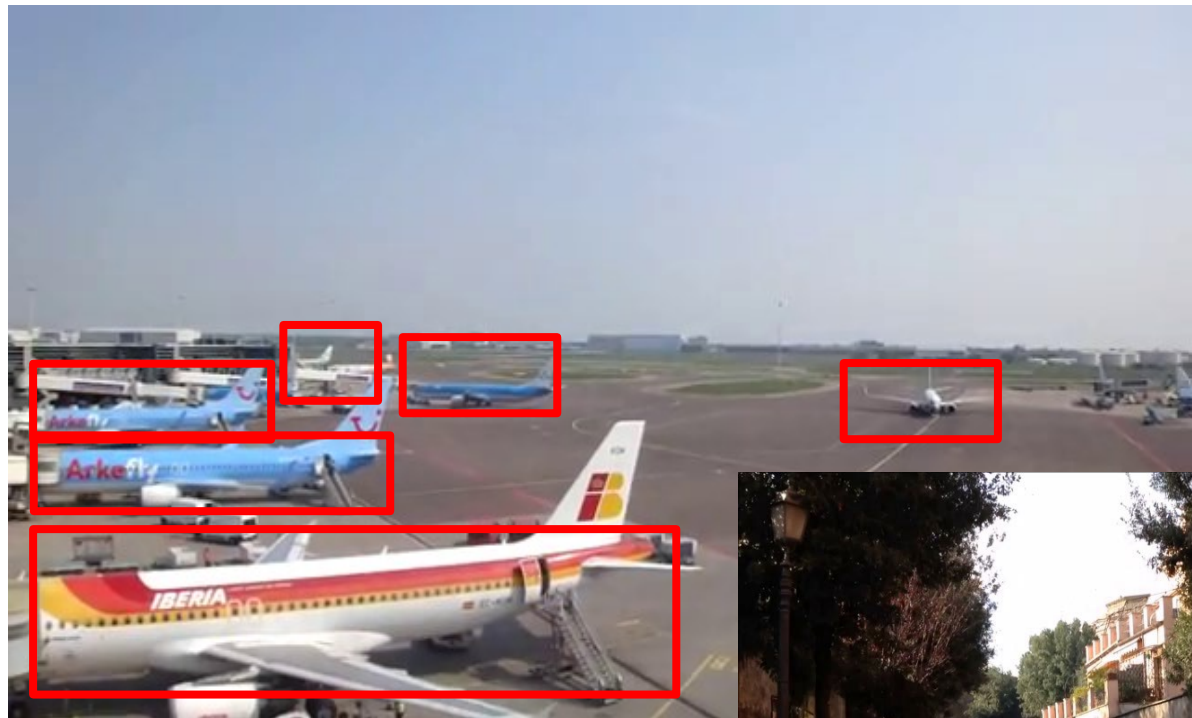

Classificazione, localizzazione, detection e segmentation

- classification



- localization



- detection



- segmentation

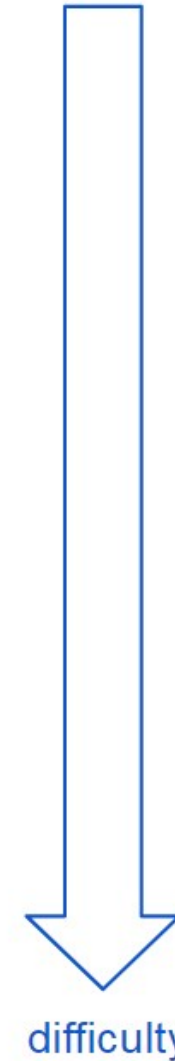
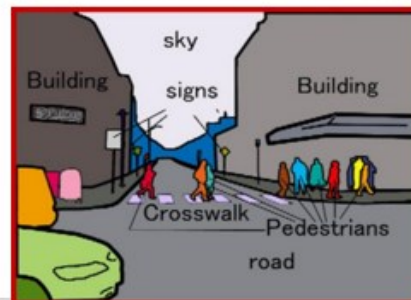

Classificazione



Barca

Lago

Acqua

Nuvole

Localizzazione



Barca 1

Barca 2

Detection

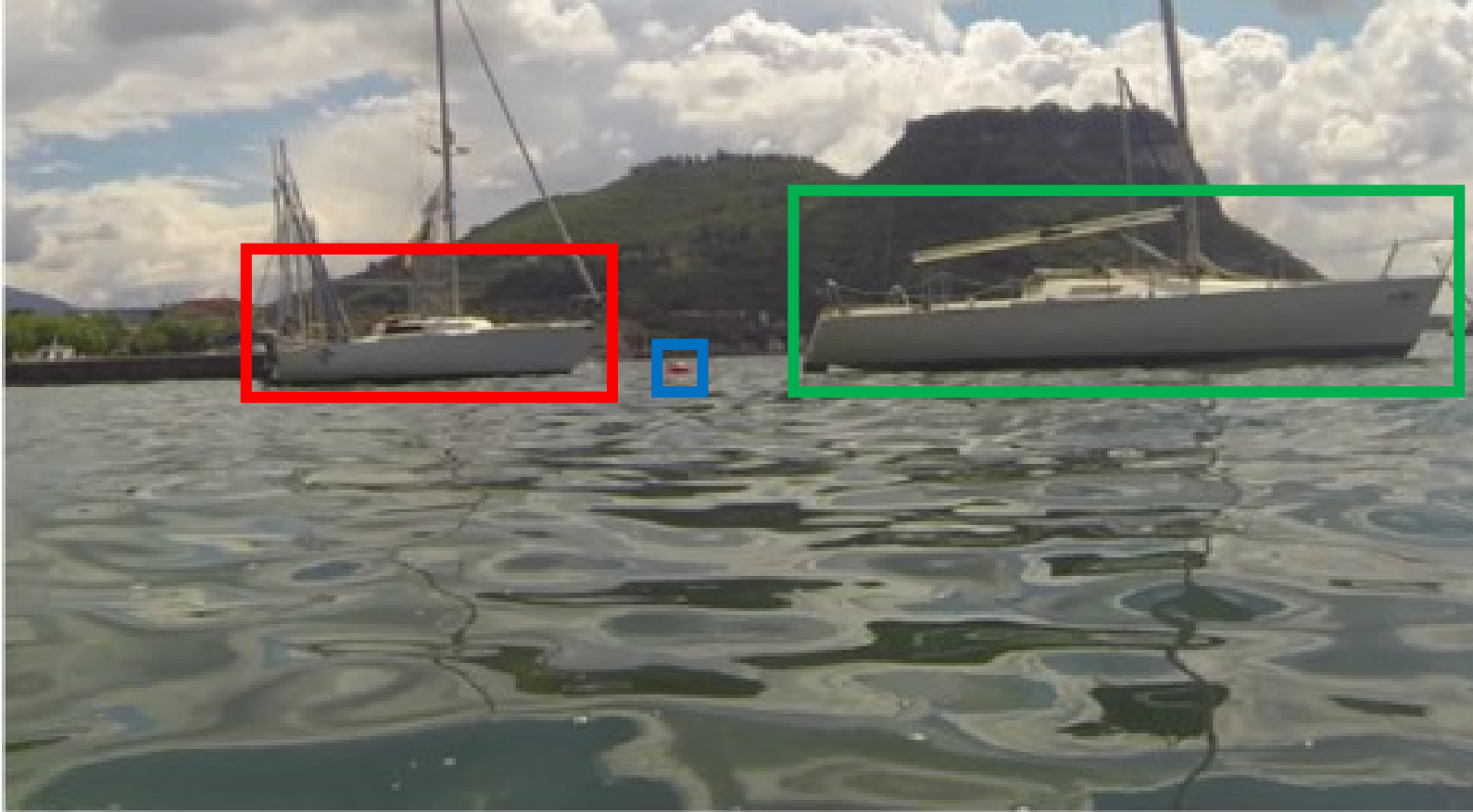





Barca 1

Barca 2

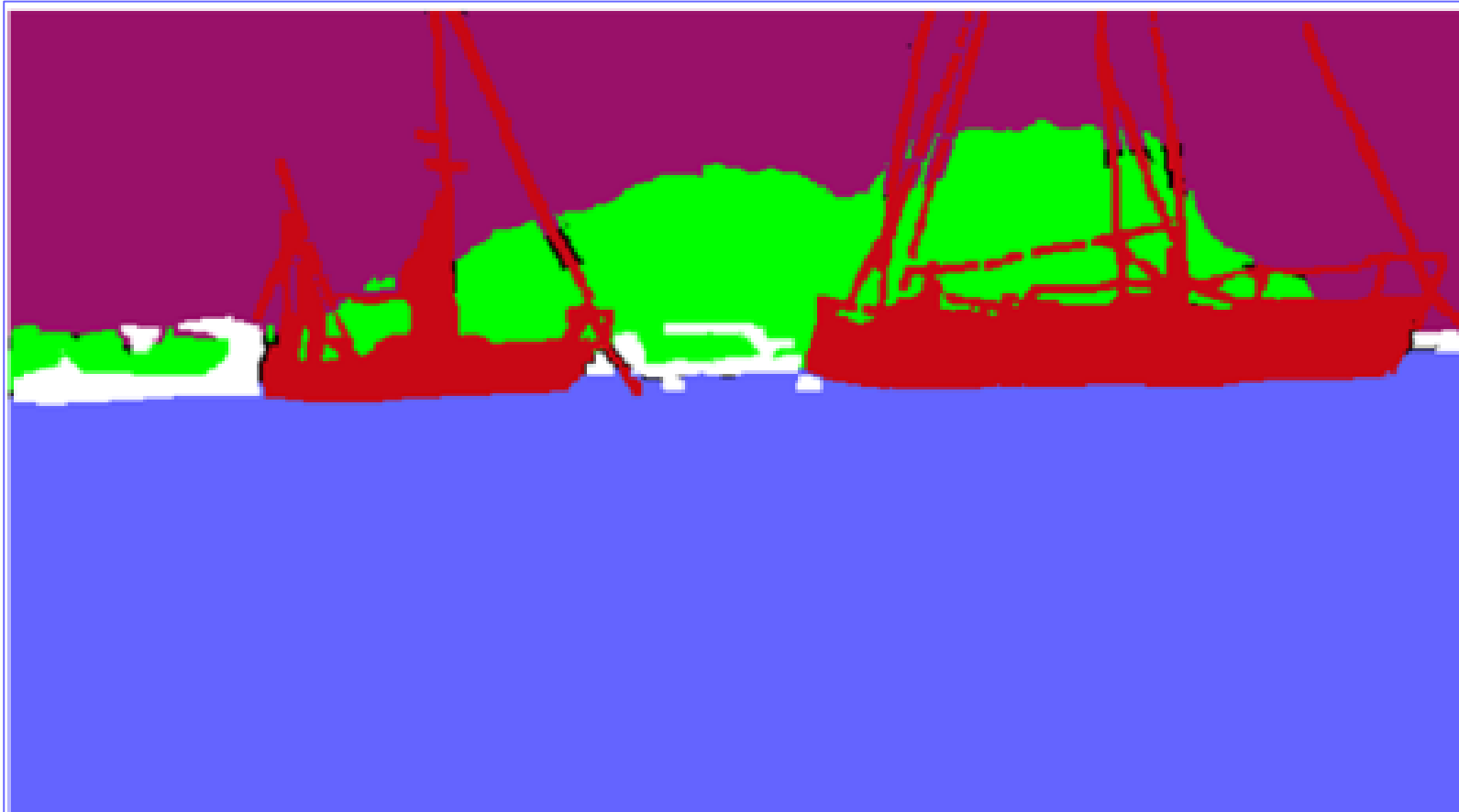
Boa 1

Segmentation



-  water
-  boat
-  vegetation
-  other

Face Detection Problem

Trovare le regioni dell'immagine contenenti una istanza della classe "faccia"



Problematiche nel Face Detection

TP
True
Positive

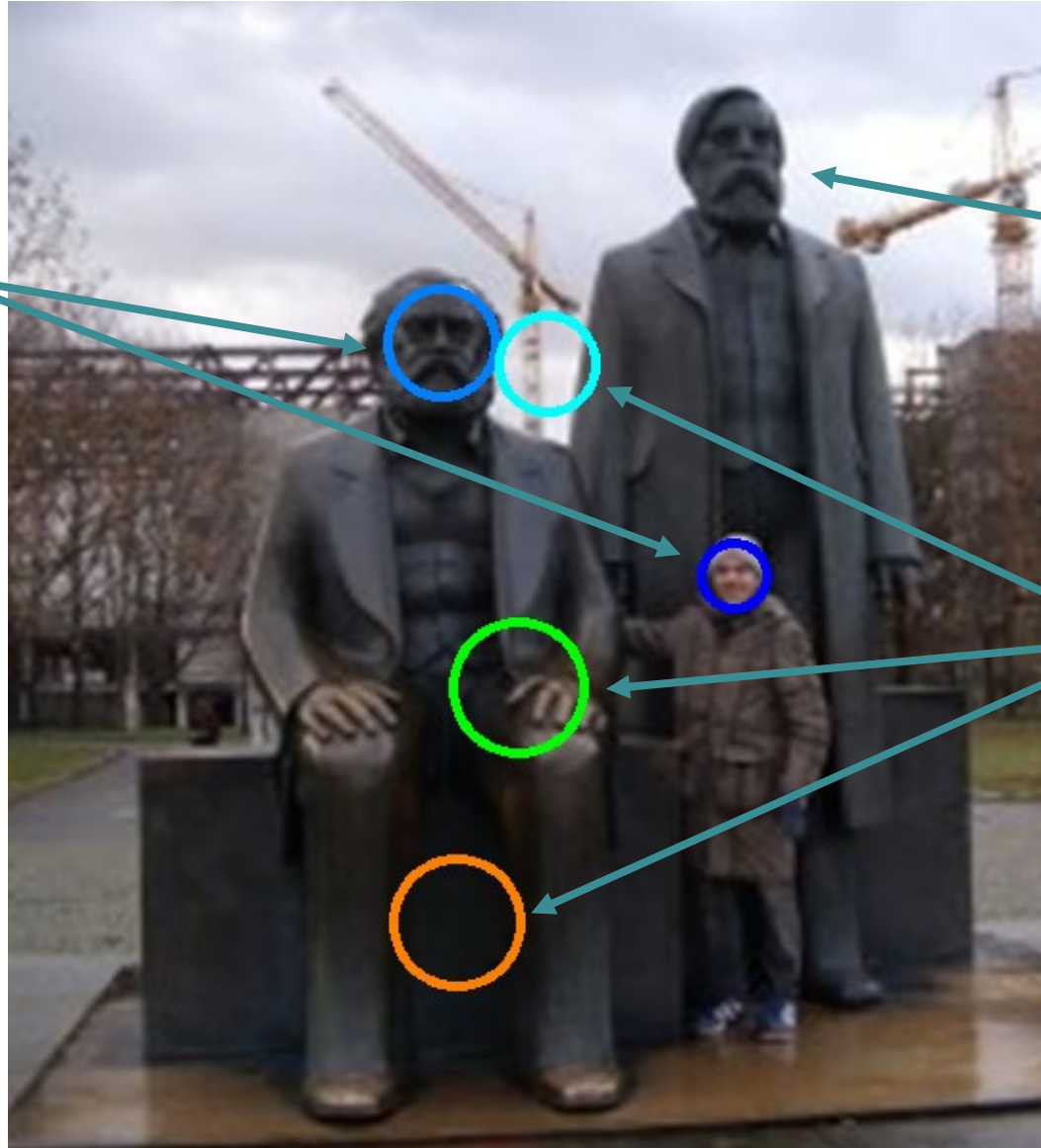

FN
False
Negative

FP
False
Positive

Problematiche aggiuntive

- Rotazione
- Blurring
- Illuminazione
- Occlusioni
- Occhiali
- ...

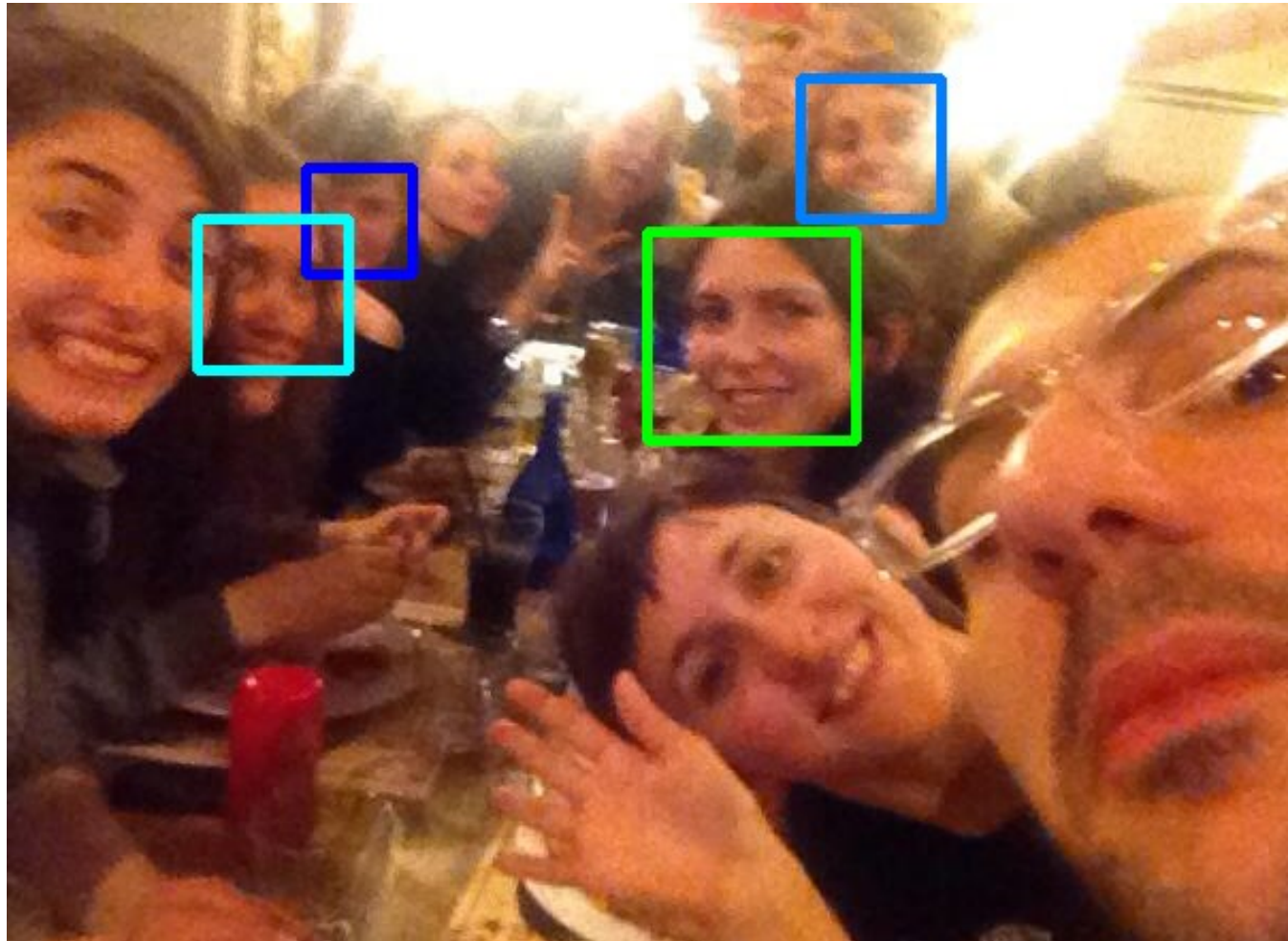

Detection vs Identification

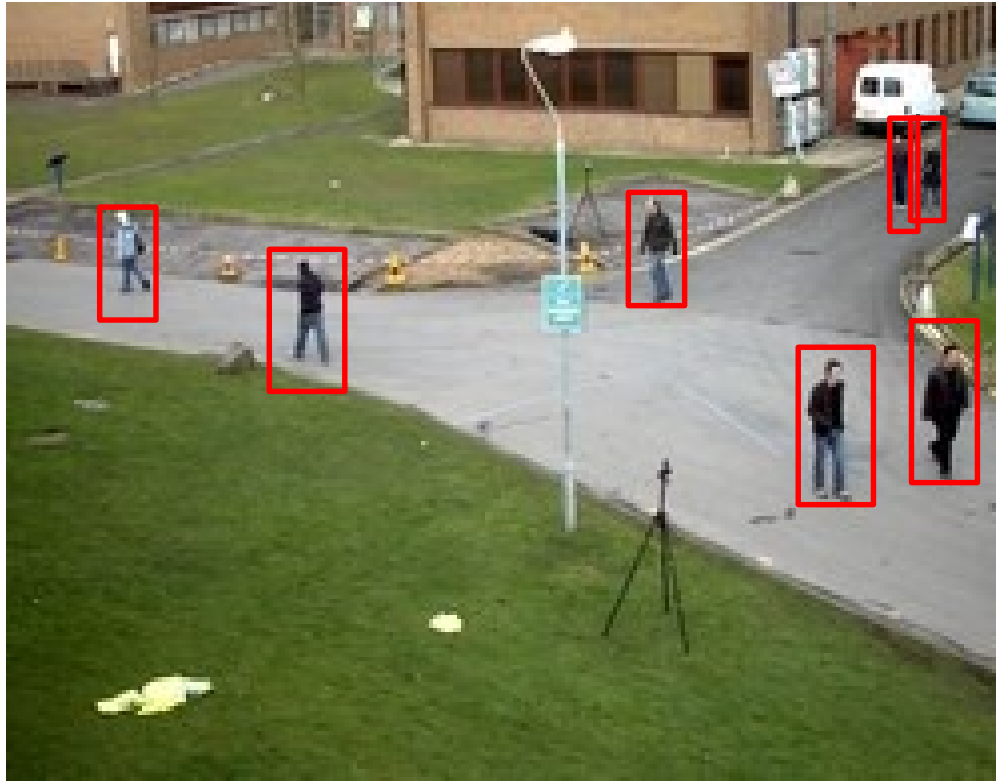

detection



identification

Detection vs Recognition

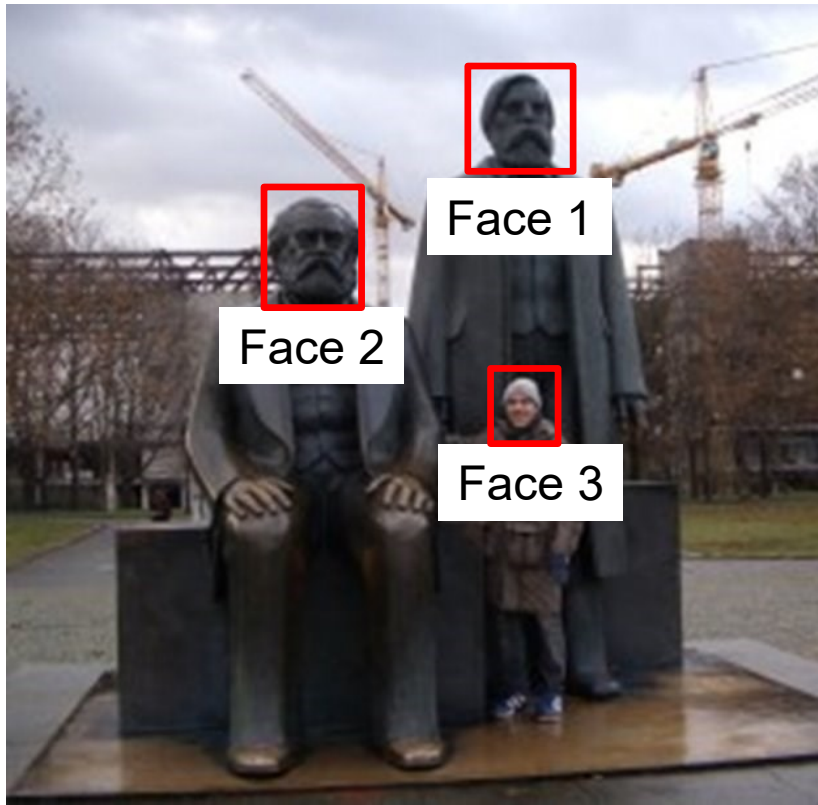

detection

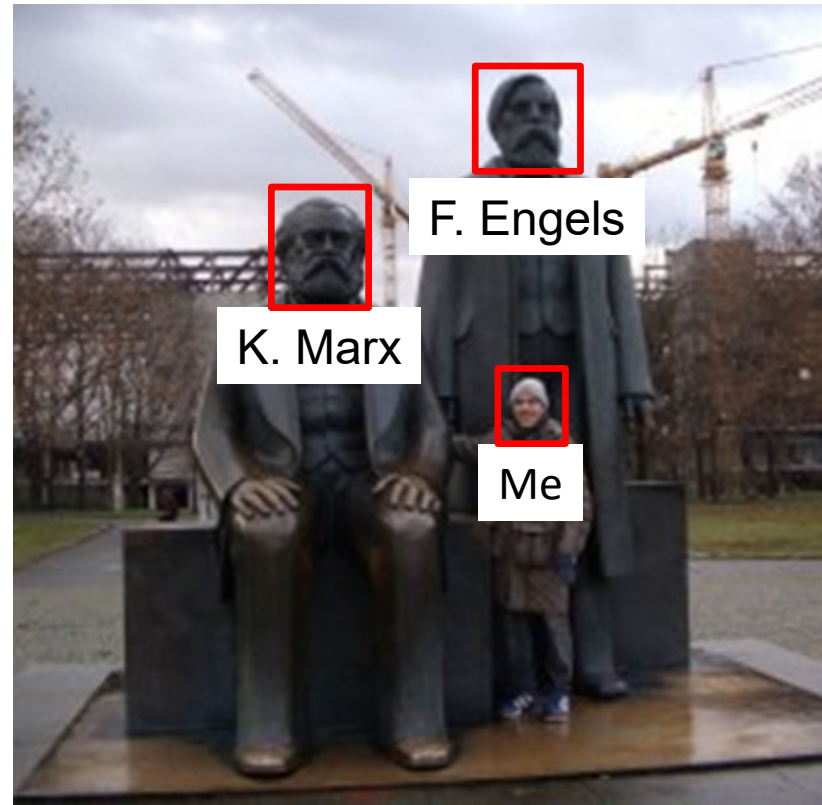

recognition

Detection & Recognition

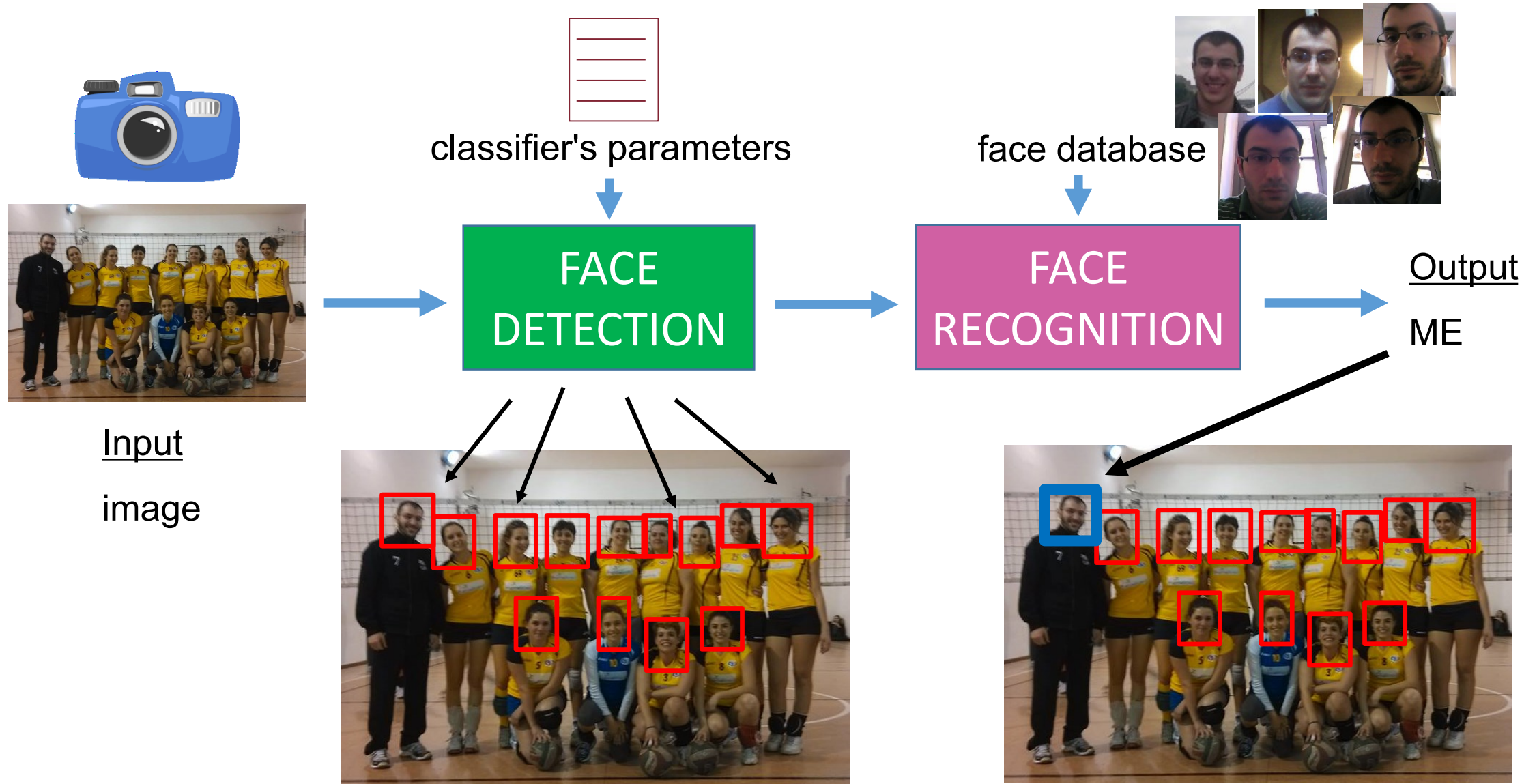

Ricerca con finestra mobile



- Si fa scorrere una finestra (per esempio 30x30) sull'immagine e si valuta se la porzione di immagine nella finestra sia corrispondente al modello dell'oggetto che si sta cercando
- L'operazione deve essere ripetuta in posizioni situate lungo tutta l'immagine
- Si assume che il numero di possibili oggetti nell'immagine sia limitato rispetto al numero delle posizioni visitate

Ricerca multiscala

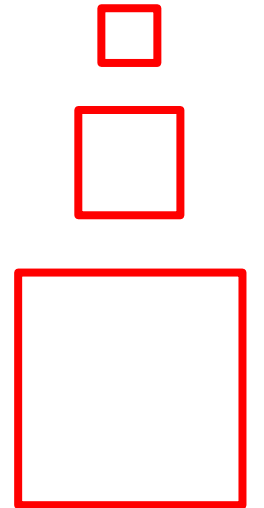

Ricerca multiscala: resize dell'input



Piramide di immagini

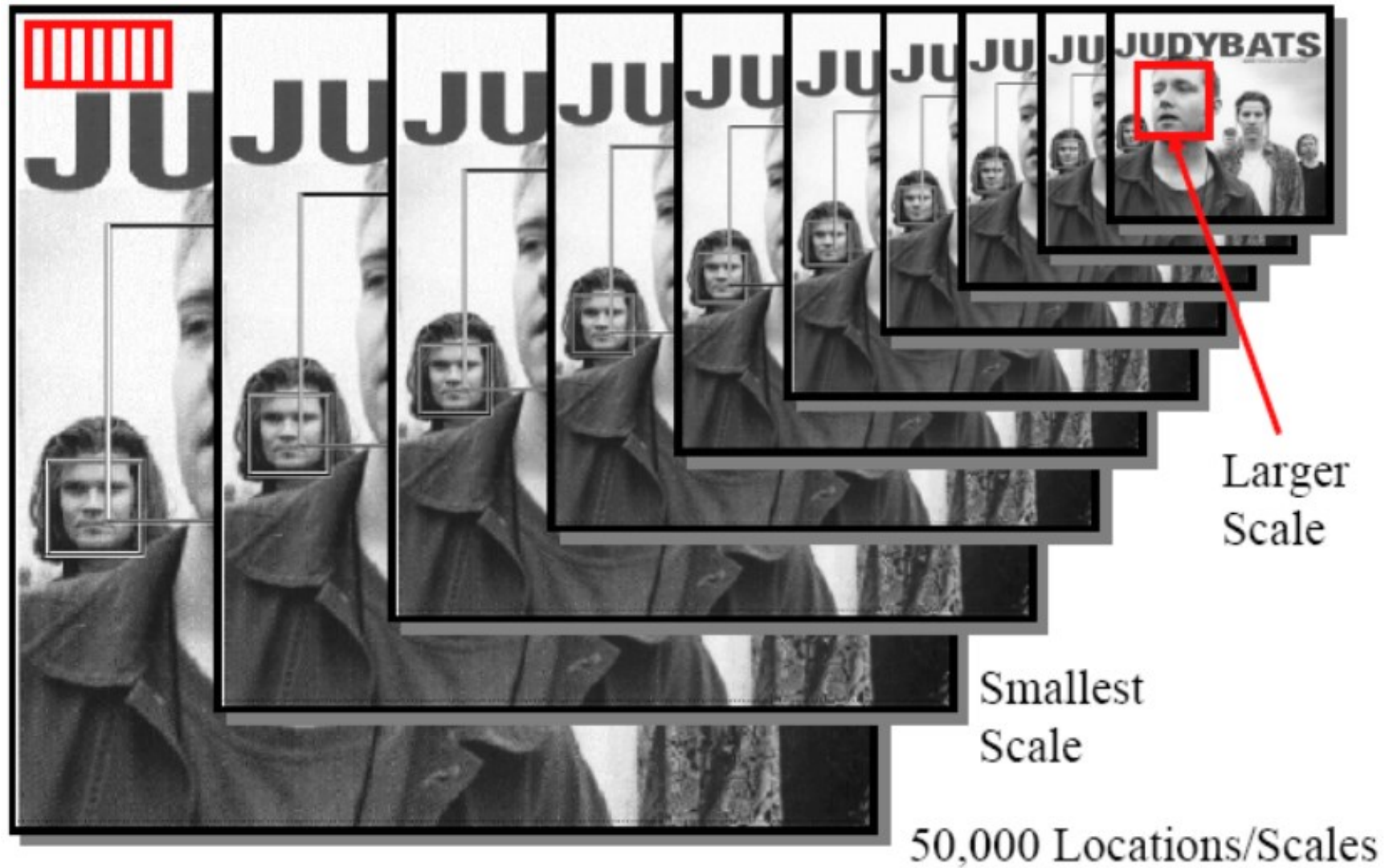

Passi per la object detection

1. Feature Computation

What features?
How can they be computed as quickly as possible?

2. Feature Selection

What are the most discriminating features?

3. Detection (in real time)

Must focus on potentially positive areas

Algoritmo di Viola and Jones

- **Very popular method**
- **Recognition is very fast**
(e.g., real-time for digital cameras)



**Training
may take
a long
time**

- **Key contributions**
 1. **Integral image for fast feature extraction**
 2. **Boosting (Ada-Boost) for face detection**
 3. **Attentional cascade for fast rejection of non-face sub-windows**

Passi nell'algoritmo di Viola and Jones

1. Feature Computation

Quick Feature Computation

Rectangle features

Integral image representation

2. Feature Selection

Simple and Efficient Classification

Ada-Boost training algorithm

3. Detection (in real time)

Real-timeliness

A cascade of classifiers

Features

Four basic types

- Easy to calculate
- White areas are subtracted from the black ones
- Integral image representation makes feature extraction faster

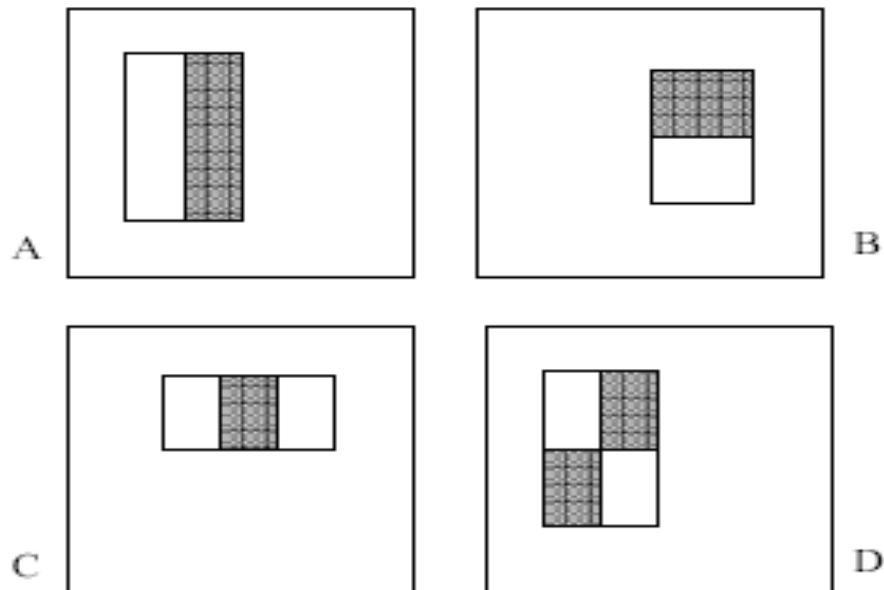

Features rettangolari

La principale motivazione dietro l'uso di features rettangolari, rispetto a filtri più espressivi, è data dalla grande efficienza computazionale che si può raggiungere usando immagini integrali



Selezione delle Features

At test time, it is impractical to evaluate the entire feature set

We want a subset of relevant features, which are informative to model a face

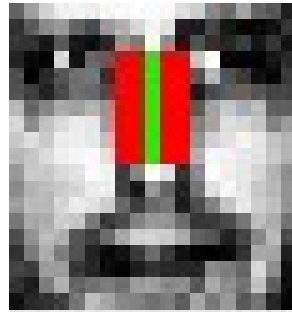

Relevant feature

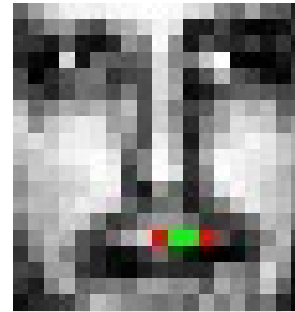

Irrelevant feature

- Can we create a good classifier using just a small subset of all possible features?
- How to select such a subset?

Features Rettangolari

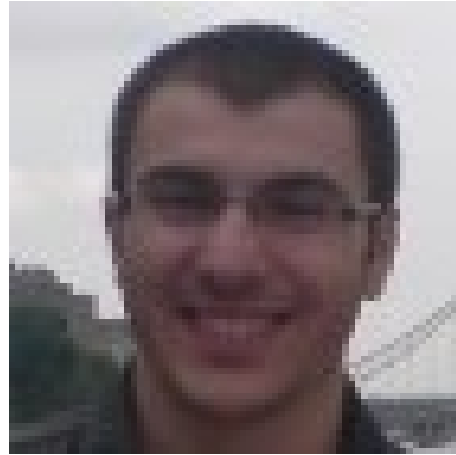

$$\text{Value} = \sum (\text{pixels in white area}) - \sum (\text{pixels in black area})$$



Features Rettangolari

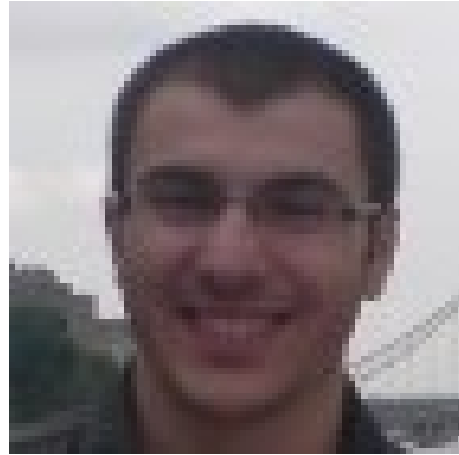

$$\text{Value} = \sum (\text{pixels in white area}) - \sum (\text{pixels in black area})$$



Cascata di classificatori

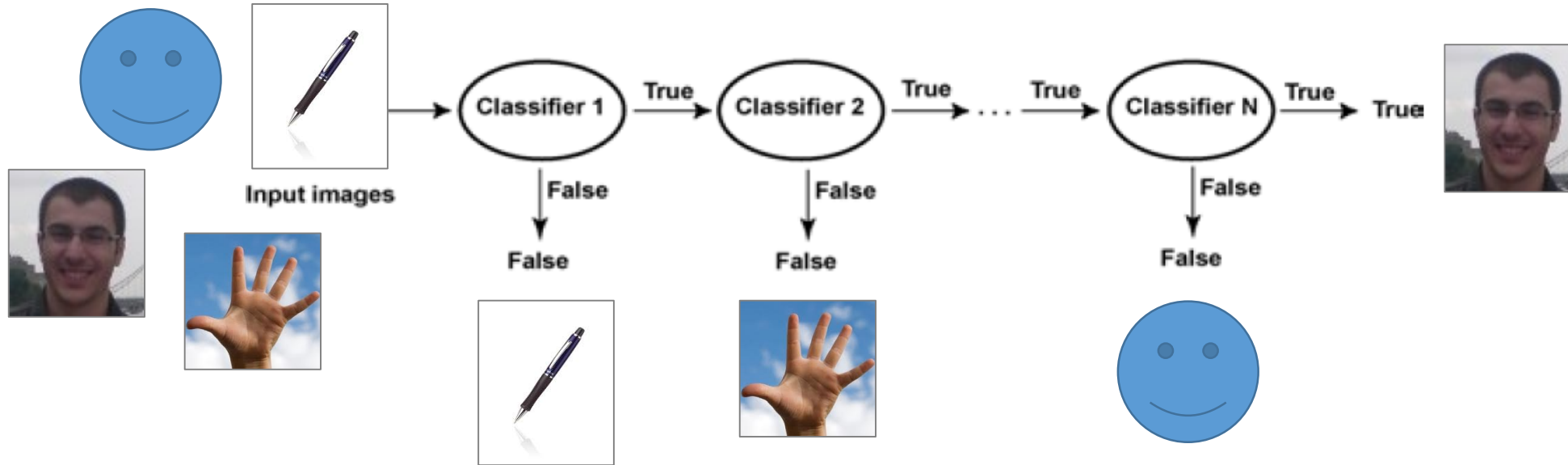

- A chain of classifiers that each reject some fraction of the negative training samples while keeping almost all positive ones
- Each classifier is an AdaBoost ensemble of rectangular Haar-like features sampled from a large pool

Face detection in fb



Face Alignment

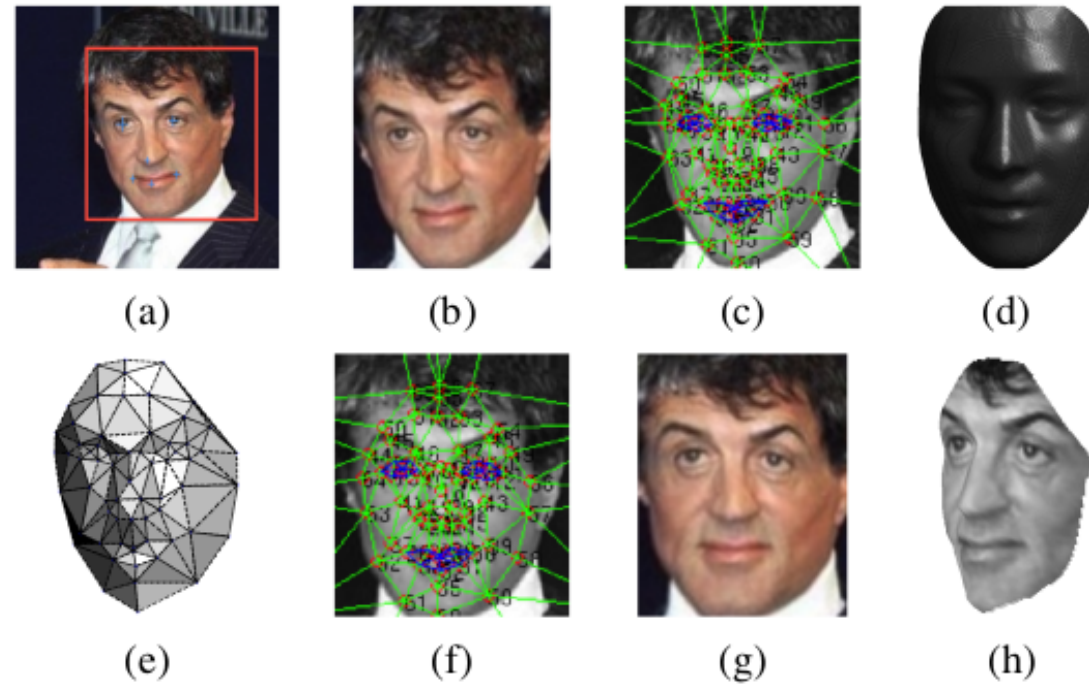

Figure 1. **Alignment pipeline.** (a) The detected face, with 6 initial fiducial points. (b) The induced 2D-aligned crop. (c) 67 fiducial points on the 2D-aligned crop with their corresponding Delaunay triangulation, we added triangles on the contour to avoid discontinuities. (d) The reference 3D shape transformed to the 2D-aligned crop image-plane. (e) Triangle visibility w.r.t. to the fitted 3D-2D camera; darker triangles are less visible. (f) The 67 fiducial points induced by the 3D model that are used to direct the piece-wise affine warping. (g) The final frontalized crop. (h) A new view generated by the 3D model (not used in this paper).

Deep Face

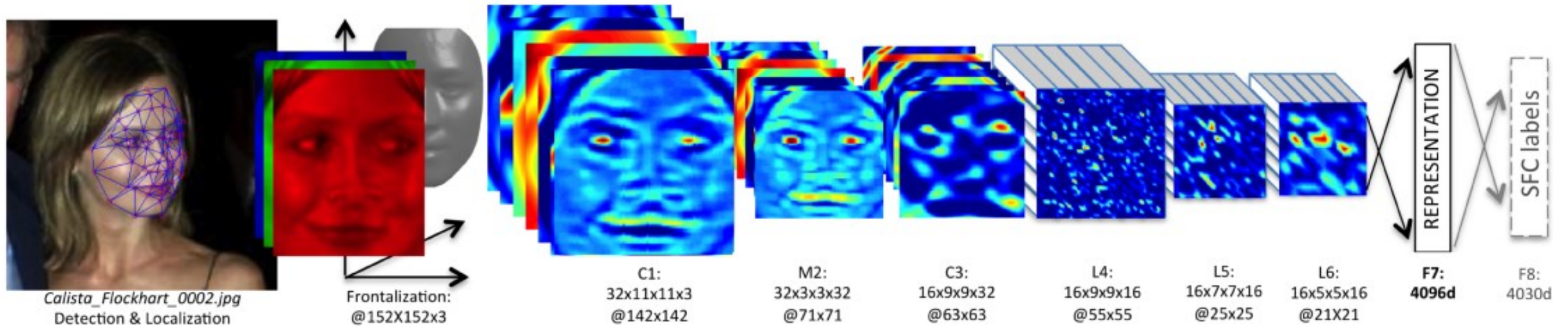

Figure 2. **Outline of the *DeepFace* architecture.** A front-end of a single convolution-pooling-convolution filtering on the rectified input, followed by three locally-connected layers and two fully-connected layers. Colors illustrate feature maps produced at each layer. The net includes more than 120 million parameters, where more than 95% come from the local and fully connected layers.

Lettura consigliata

Y. Taigman, M. Yang, M. Ranzato, L. Wolf, "DeepFace: Closing the Gap to Human-Level Performance in Face Verification," in IEEE Conference on Computer Vision and Pattern Recognition, pp. 1701-1708, 2014

References and Credits

- P. Sermanet, “Object Detection with Deep Learning”
- K.H. Wong. “Ch. 6: Face detection”
- P. Viola and T.-W. Yue. “Adaboost for Face Detection”
- D. Miller. “Face Detection & Synthesis using 3D Models & OpenCV”
- S. Lazebnik. “Face detection”
- C. Schmid. “Category-level localization”
- C. Huang and F. Vahid. “Scalable Object Detection Accelerators on FPGAs Using Custom Design Space Exploration”
- P. Smyth. “Face Detection using the Viola-Jones Method”
- K. Palla and A. Kalaitzis. “Robust Real-time Face Detection”



UNIVERSITÀ
di **VERONA**

Dipartimento
di **INFORMATICA**

Corso di Laboratorio Ciberfisico
Modulo di Robot Programming with ROS

Percezione *visione*

Docente:
**Domenico Daniele
Bloisi**

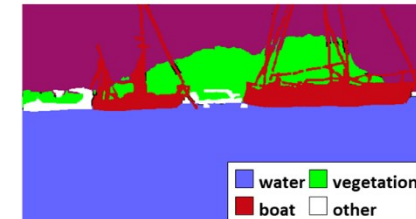
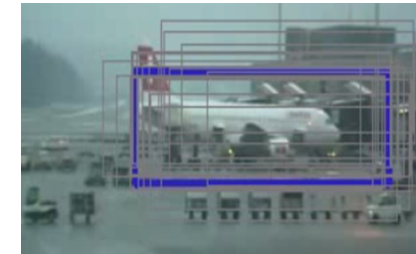

Maggio 2018

